

BU FESSEELA WAREHOUSING PARK

UMM SALAL, DOHA

Managed By **GWC**

Supported By



بوفسيلة
Bu Fesseela

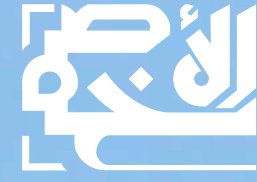

LIVE.WORK.SHOP

Bu Fesseela Warehousing Park City is an all encompass facility dedicated to support small to medium sized enterprises. Located in Bu Fesseela- Umm Salal area, the 500,000 m2 of land was conceptualized and developed by Al Asmakh Real Estate Development Company. The mixed use development, supported by Manateq Economic Zones Company, and Managed by Gulf Warehousing Company, incorporates the Live, Work and Shop concept with features including staff Accommodation, Apartments, Warehouses and Retail Shops.



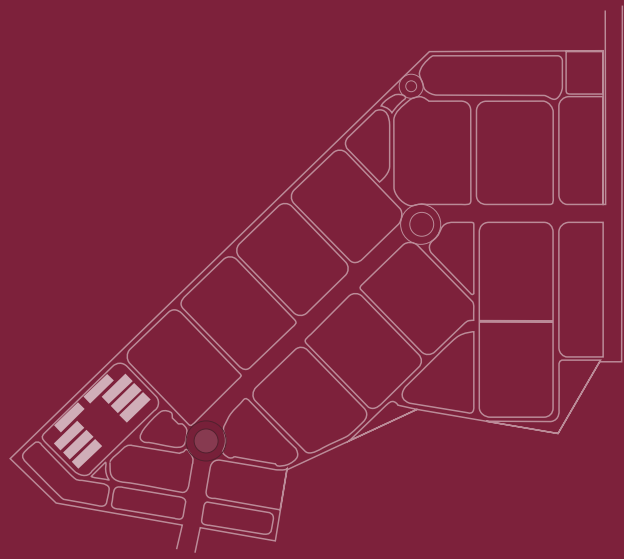

LIVE
HOUSING ACCOMMODATION

STAFF ACCOMMODATION

The residential component consists of 576 rooms.

The rooms are unfurnished with air conditioning and attached bathroom. Each floor has two kitchens & two laundries.



GROUND FLOOR

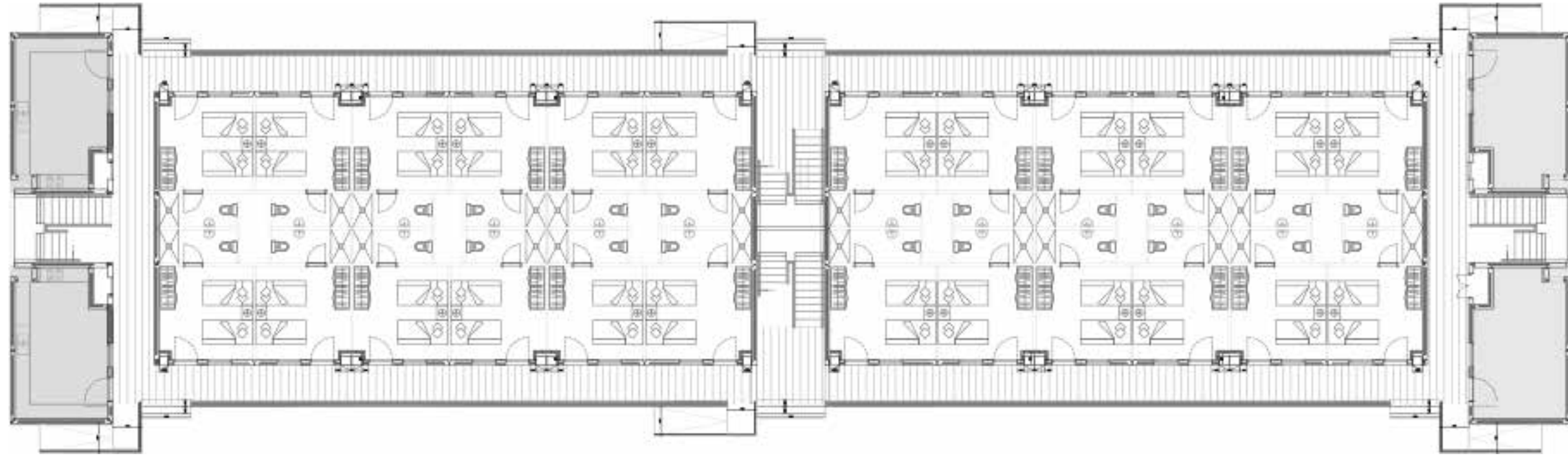

LAUNDRY

KITCHEN

TYPICAL FLOOR

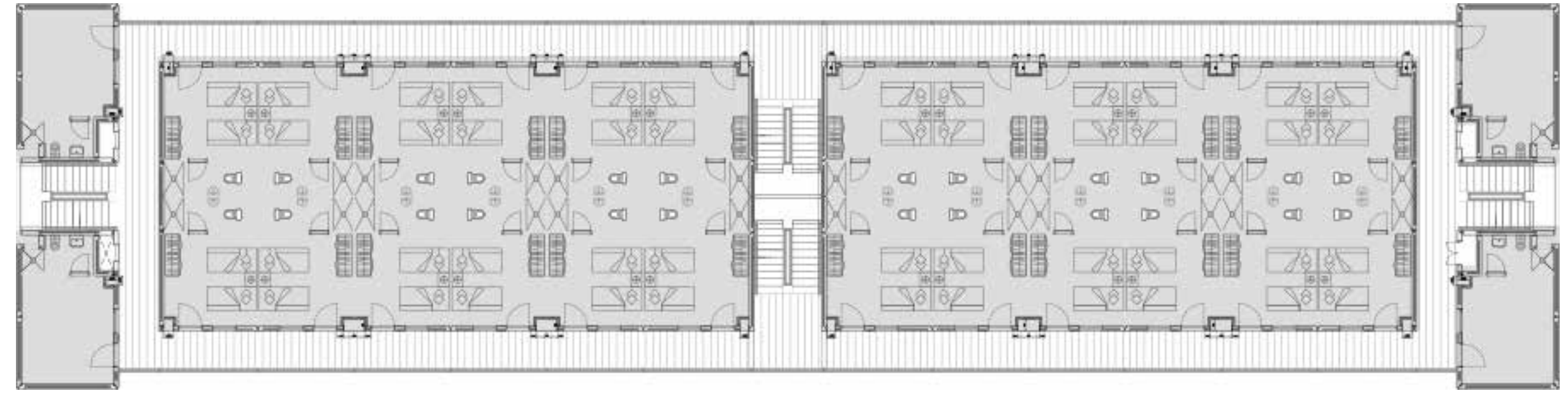

ROOM

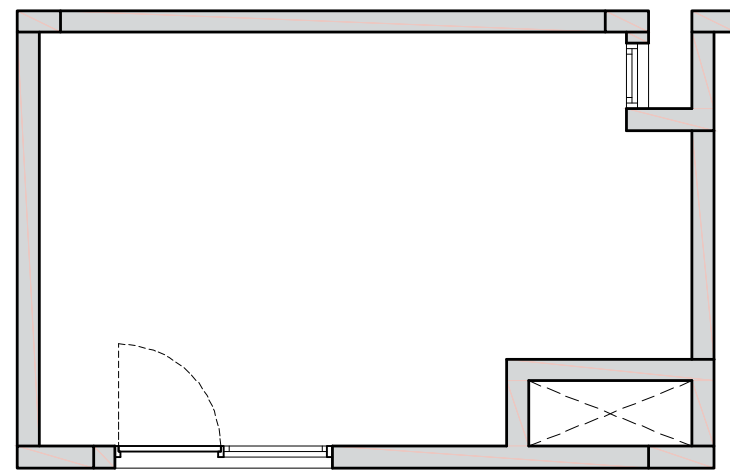

LAUNDRY
6000X3800

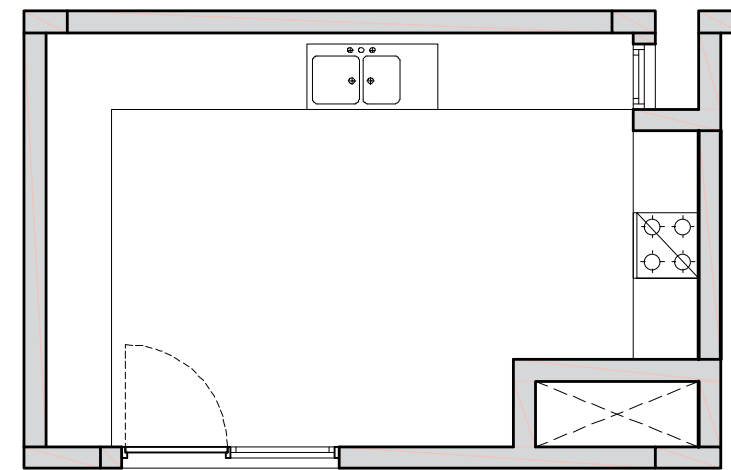

KITCHEN
6000X3800

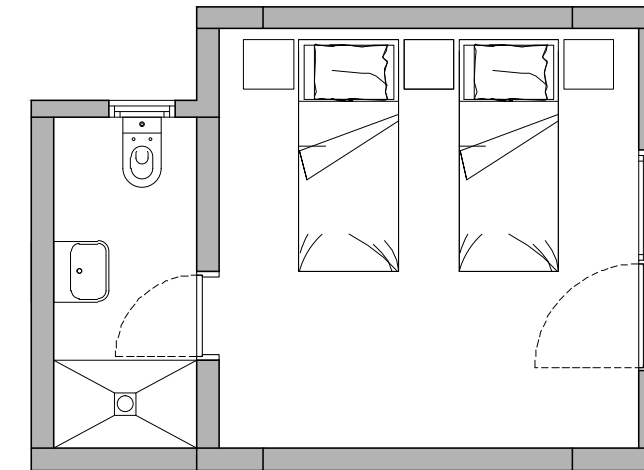

ROOM
ROOM. 3800X3900 | BATH. 1300X3000

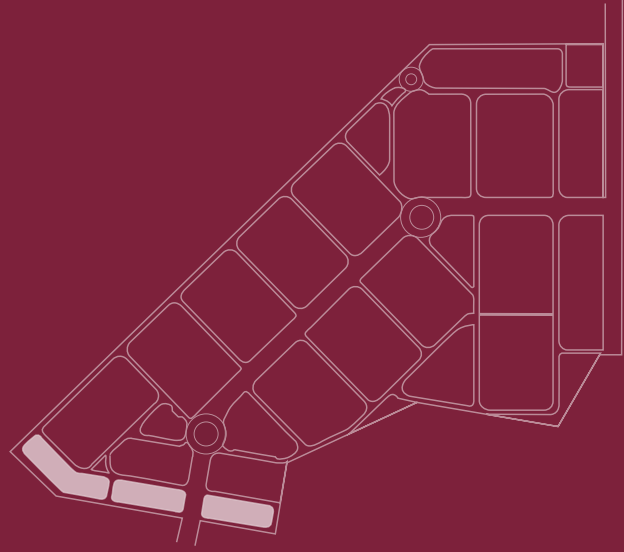

LIVE

RESIDENTIAL APARTMENTS

APARTMENTS

The residential component consists of 262 apartments.

Studio Apartments, 194 units, are semi-furnished and include a kitchenette, bathroom and a bedroom.

One-Bedroom Apartments, 70 units, are semi-furnished, including a kitchenette, bathroom, bedroom and a living space.



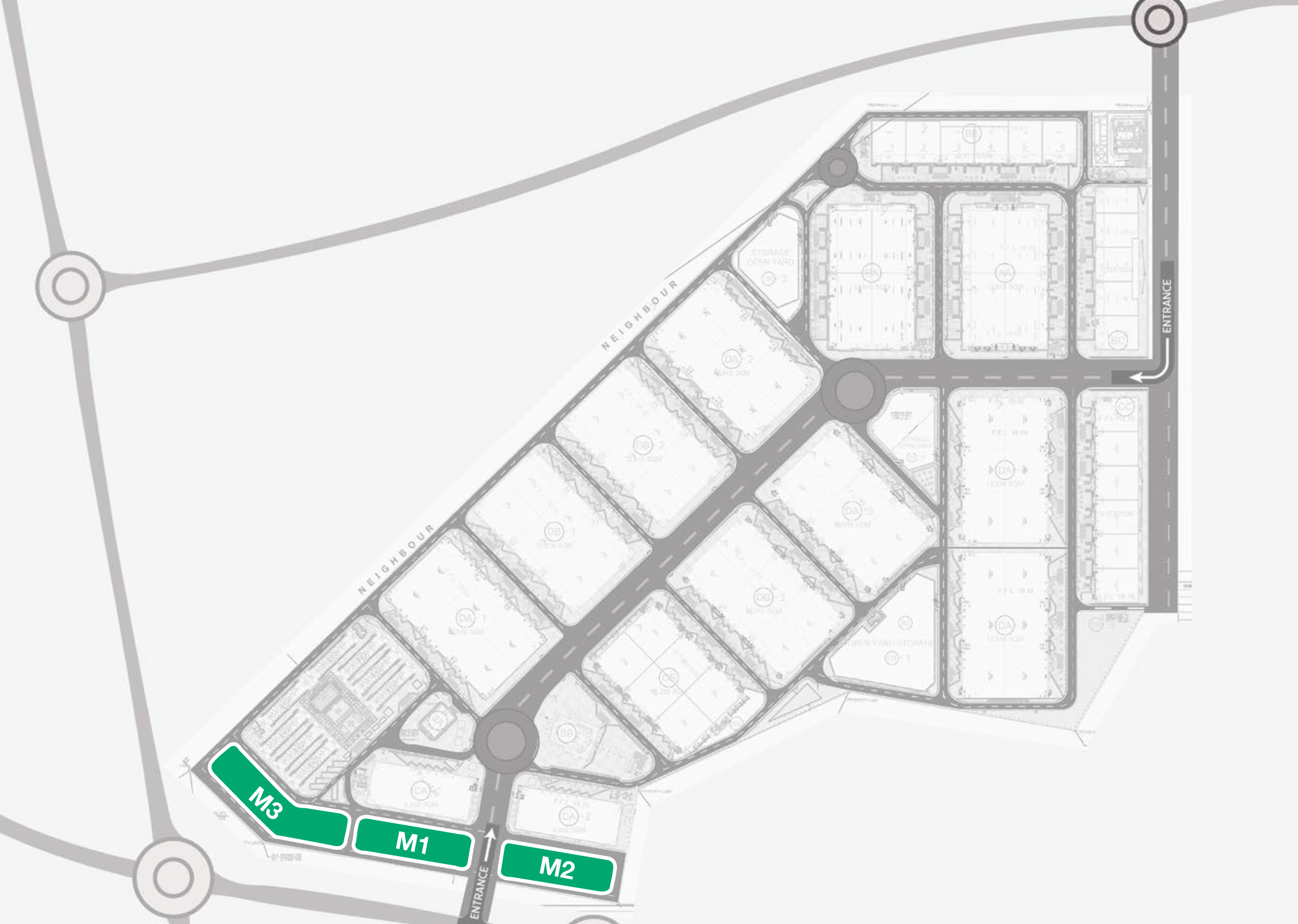

APARTMENTS

- M1
- M2
- M3

M1,M2- FIRST & SECOND FLOOR

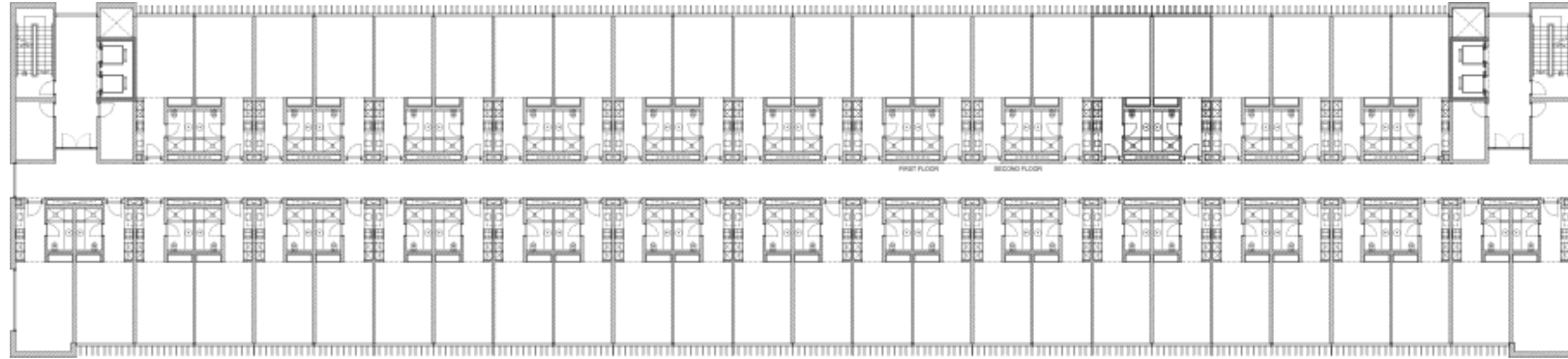

M1/M2 FIRST FLOOR
STUDIO APARTMENTS

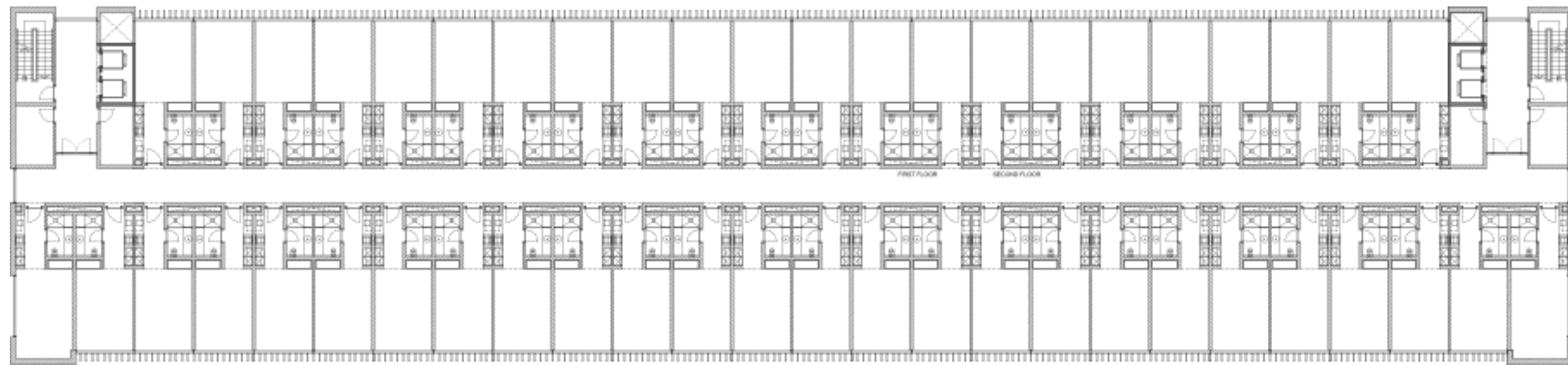

M1/M2 SECOND FLOOR
STUDIO APARTMENTS

APARTMENTS TYPES

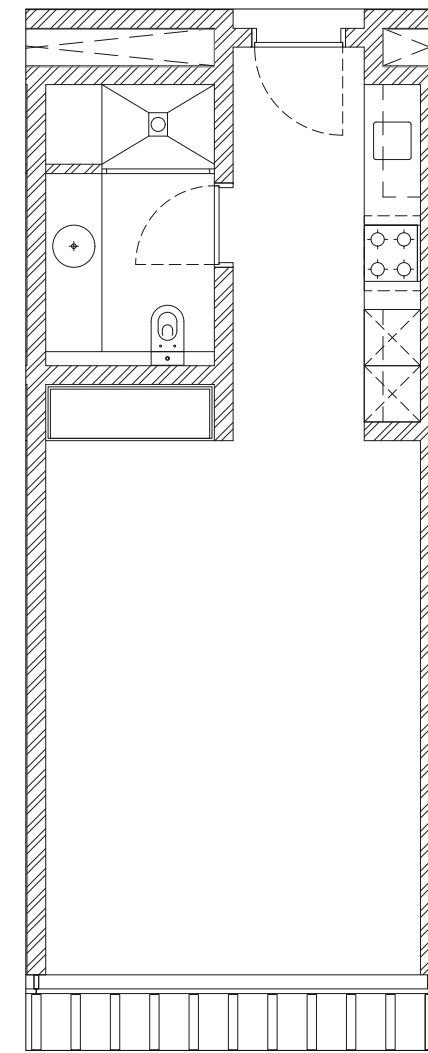

STUDIO TYPE A
37.5 M²
Room-4m x 5.7m, Bathroom-1.8m x 3m,
Hall way/ Kitchen-4.4m x 2 m

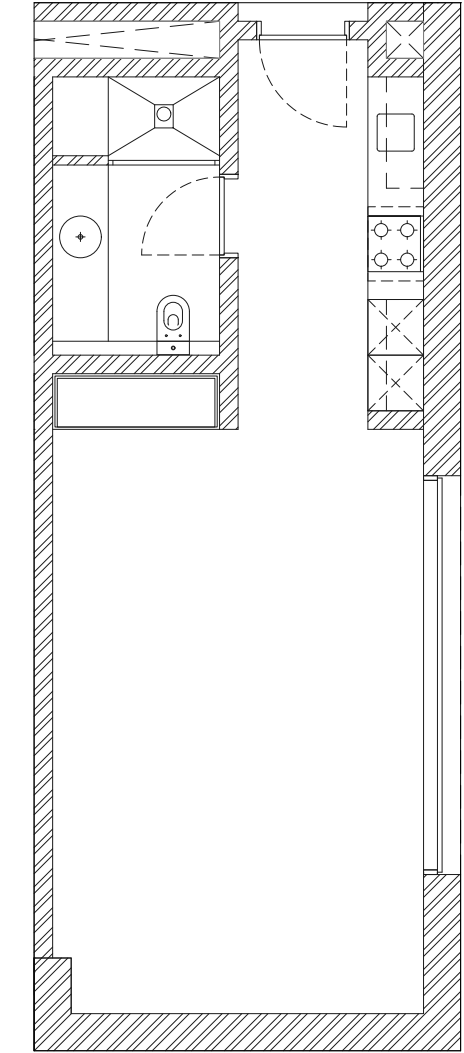

STUDIO TYPE B
40 M²
Room-4m x 6.3m, Bathroom-1.8m x 3m,
Hall way/ Kitchen-4.2m x 2.1 m

Type A: 182 Flats
Type B: 8 Flats

M3- FIRST & SECOND FLOOR

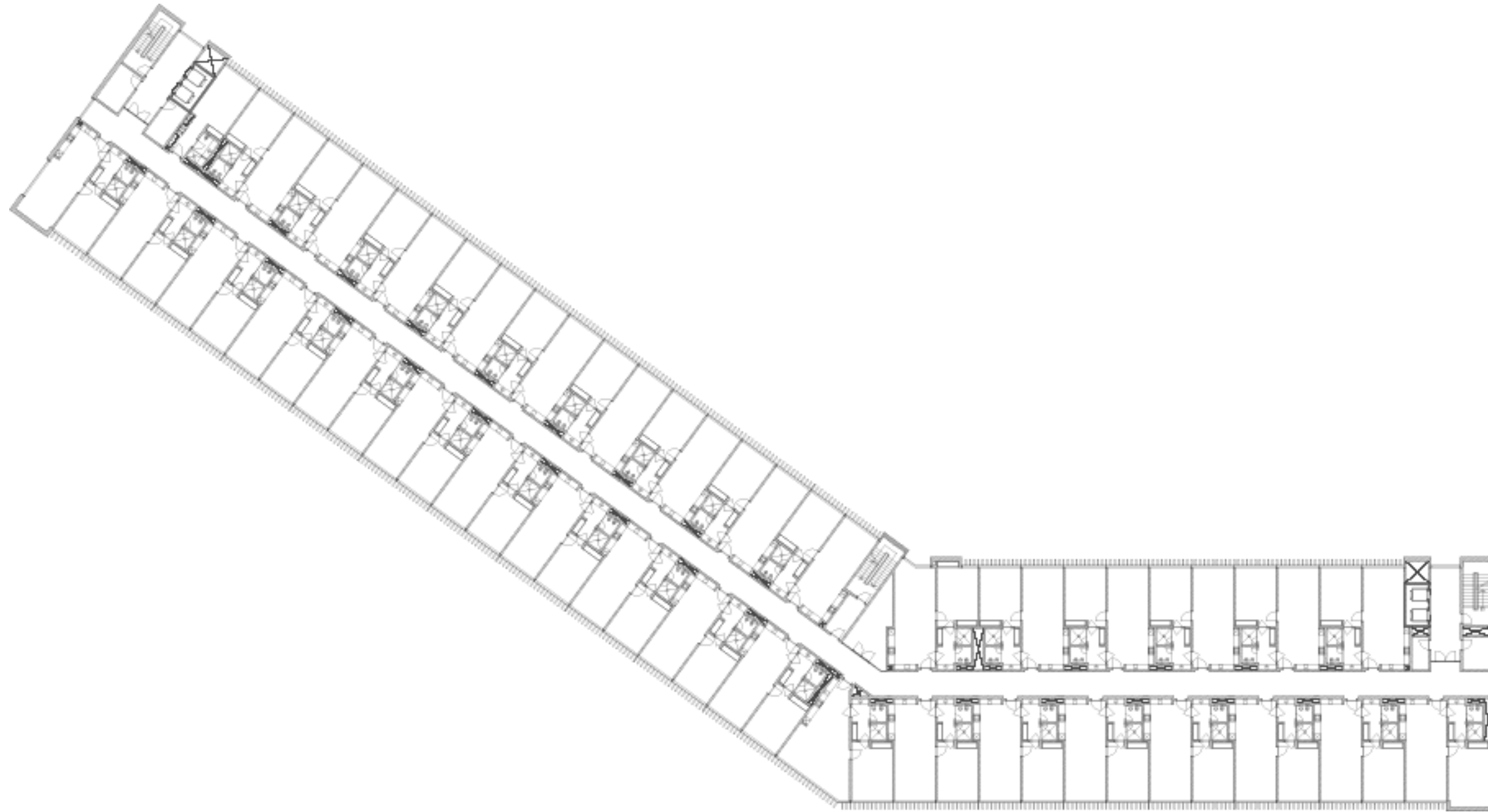

M3 FIRST/SECOND FLOOR
STUDIO & 1-BEDROOM APARTMENTS

APARTMENTS TYPES

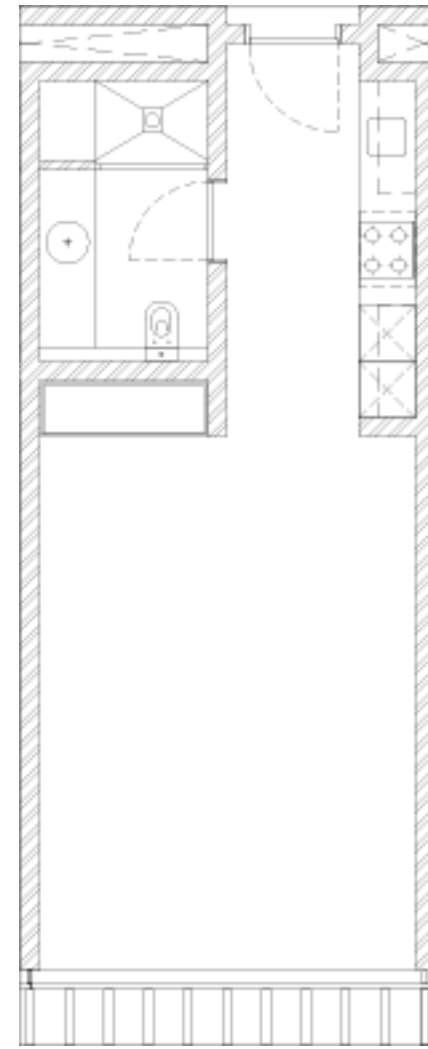

STUDIO TYPE A
37.5 M²

Room-4m x 5.7m, Bathroom-1.8m x 3m,
Hall way/ Kitchen-4.4m x 2 m

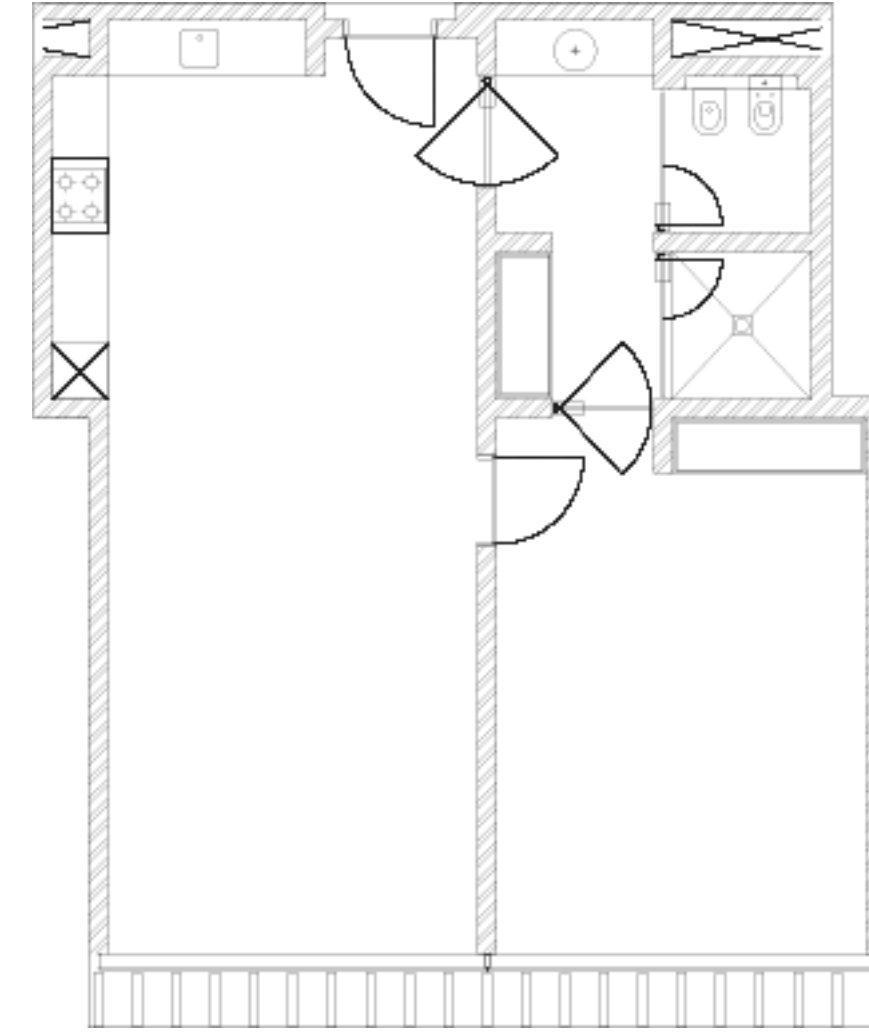

1-BEDROOM TYPE A
80 M²

Room-4m x 5.8m, Bathroom-3.4m x 3.5m,
Kitchen-4m x 4m, Living/Dining-6m X 4m

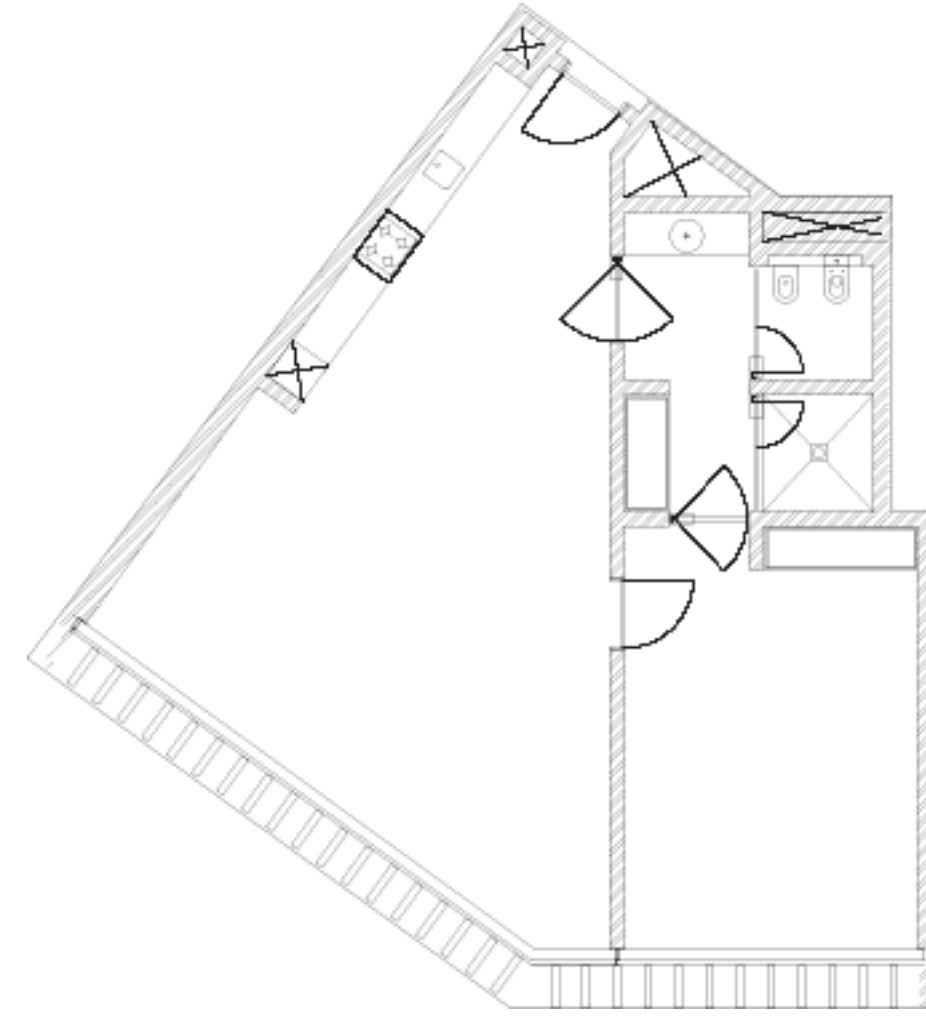

1-BEDROOM TYPE B
90 M²

Room-4m x 5.8m, Bathroom-3.4m x 3.5m,
Kitchen-20M², Living/Dining-6.3m X 5m

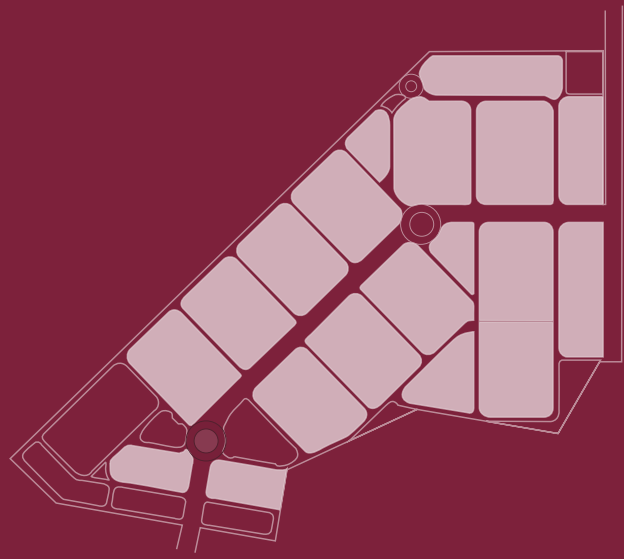

WORK
WAREHOUSES

WAREHOUSES

Total space of 207,222 m²

Open yard storage areas, ventilated warehouses, air conditioned warehouses, chilled warehouses and frozen storage warehouses.

Each storage warehouse encloses a toilet and a pantry located either on the ground level or on the mezzanine partition.



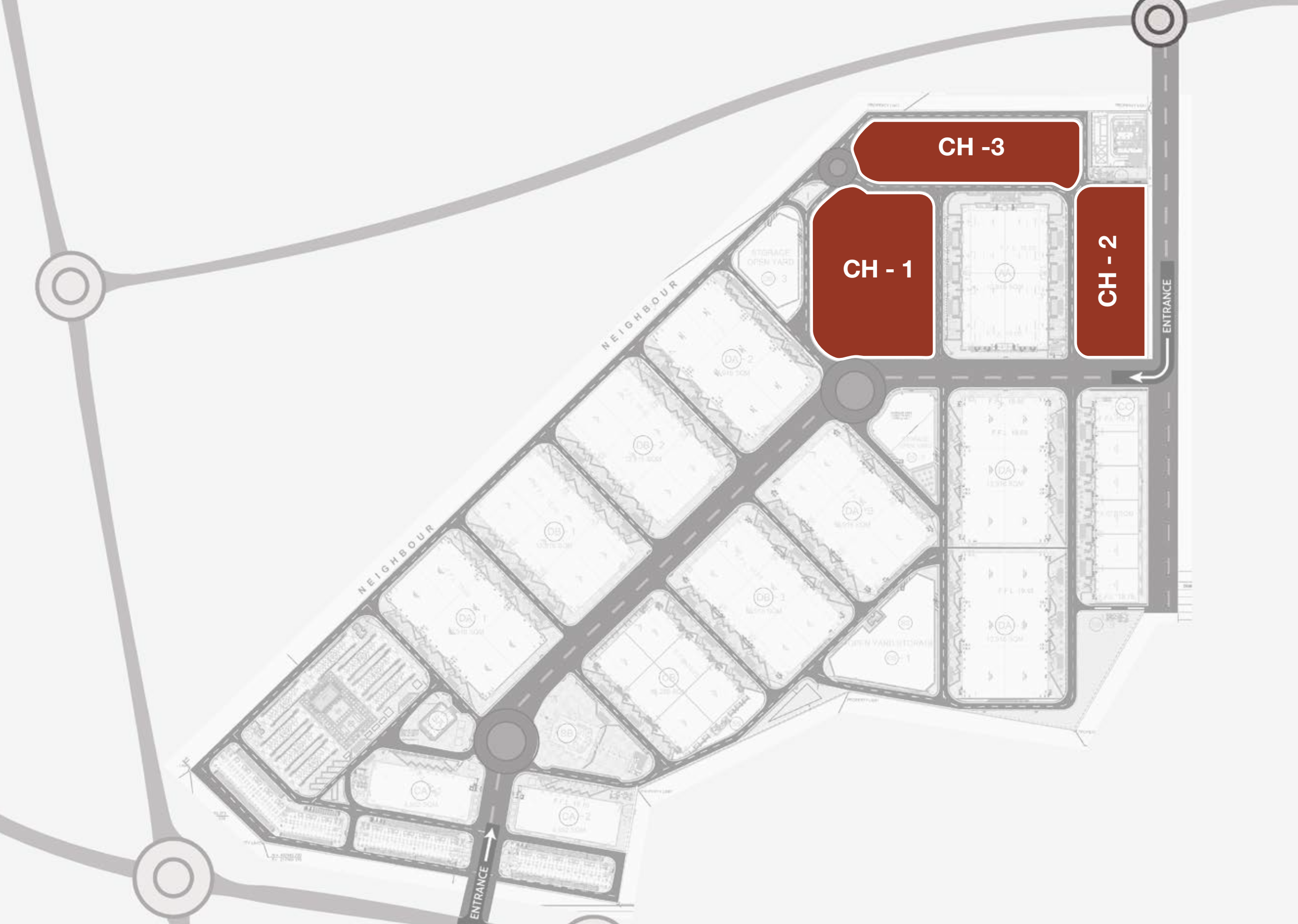

CHILLED WAREHOUSES

CH-1 (Ground Floor, Mezzanine Floor)

CH-2 (Ground Floor, Mezzanine Floor)

CH-3 (Ground Floor, Mezzanine Floor)

CHILLED-CH1-GROUND FLOOR

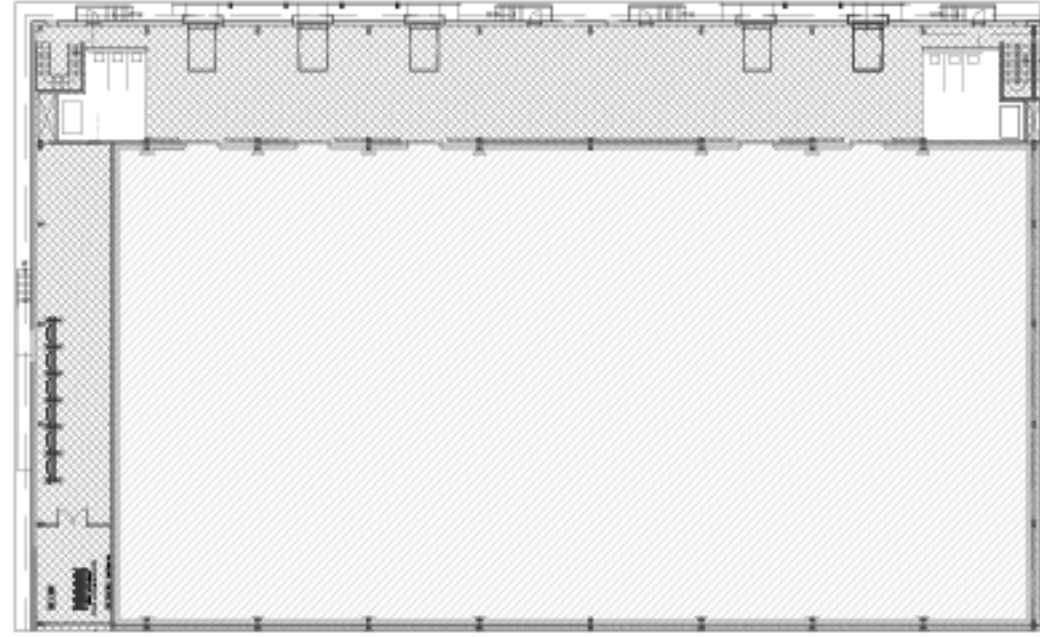
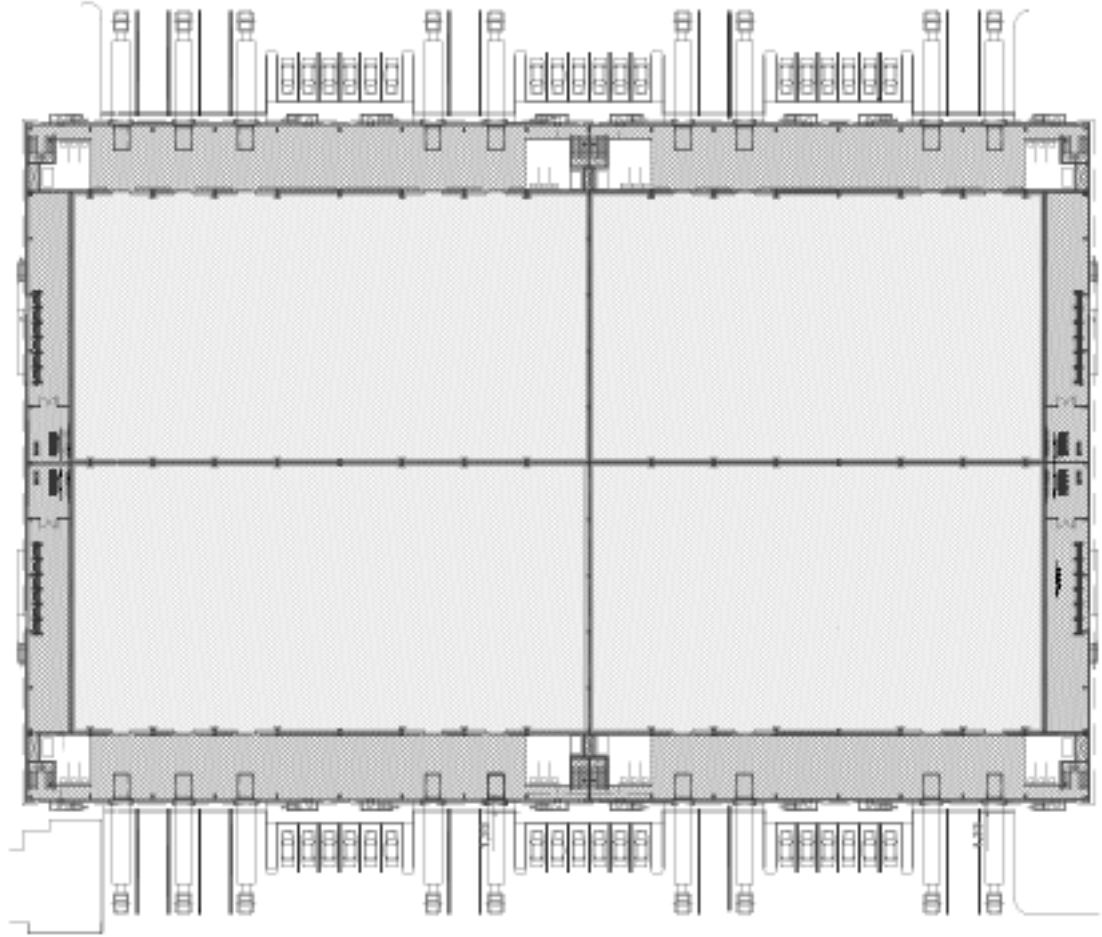

TYPE A
3,605 M²

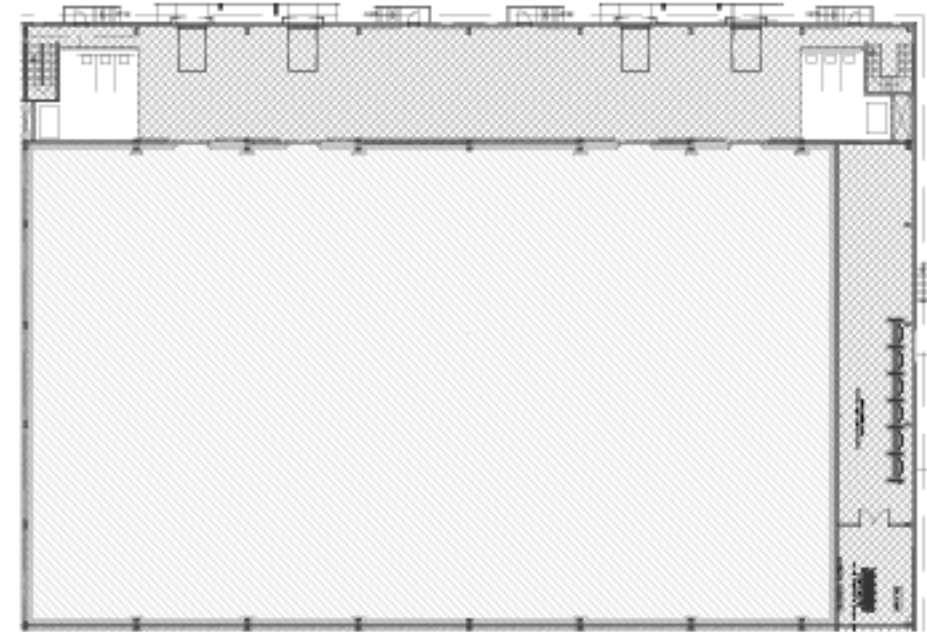

TYPE B
3,212 M²

CHILLED-CH1-MEZZANINE FLOOR

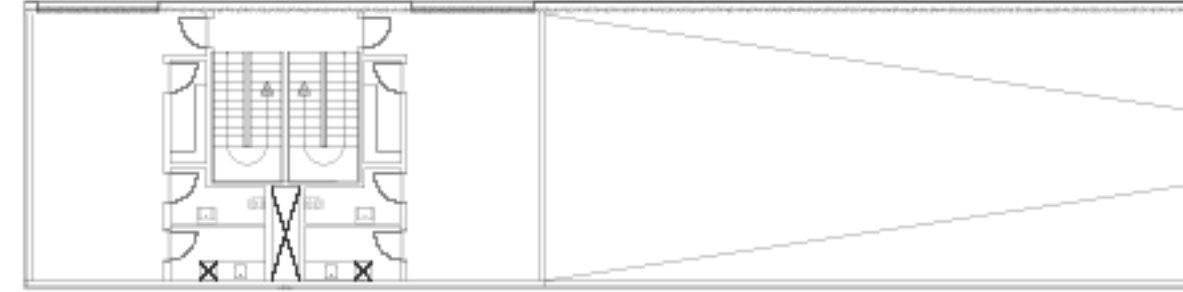
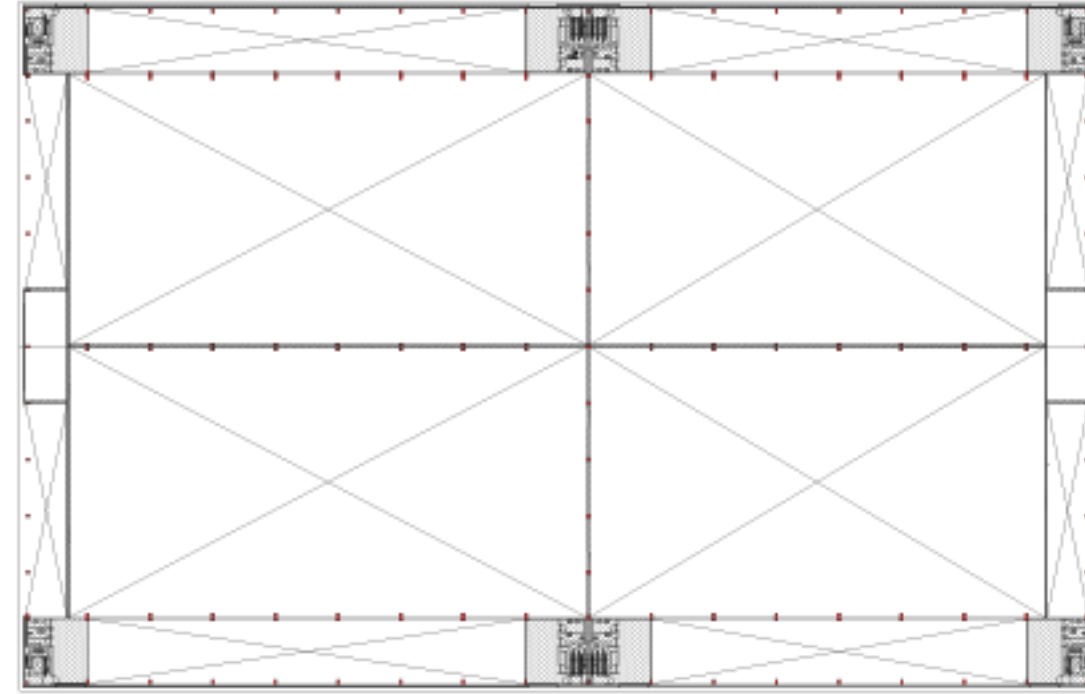

Each Warehouse has an Office of 77 m², including a pantry and a bathroom in the Mezzanine floor.

CHILLED-CH2-GROUND FLOOR

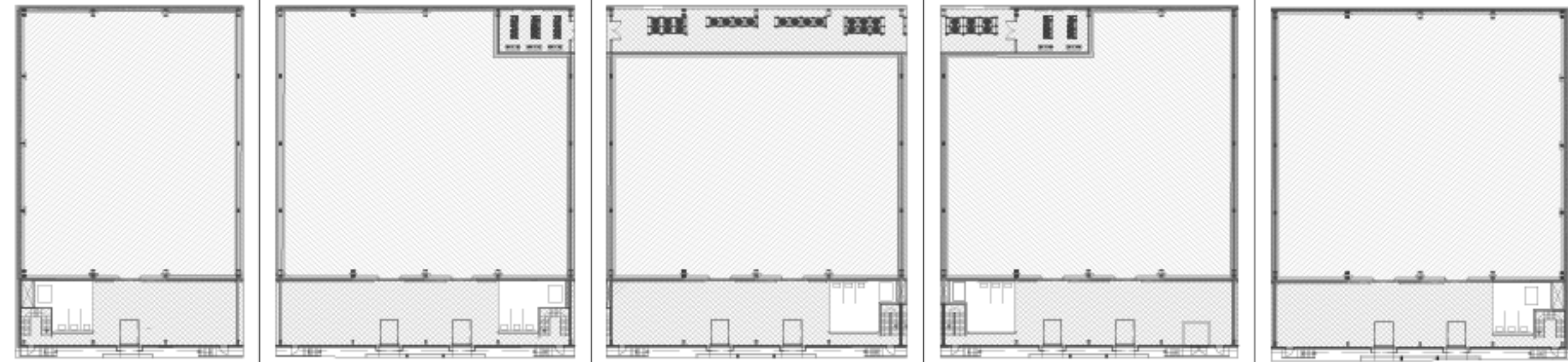
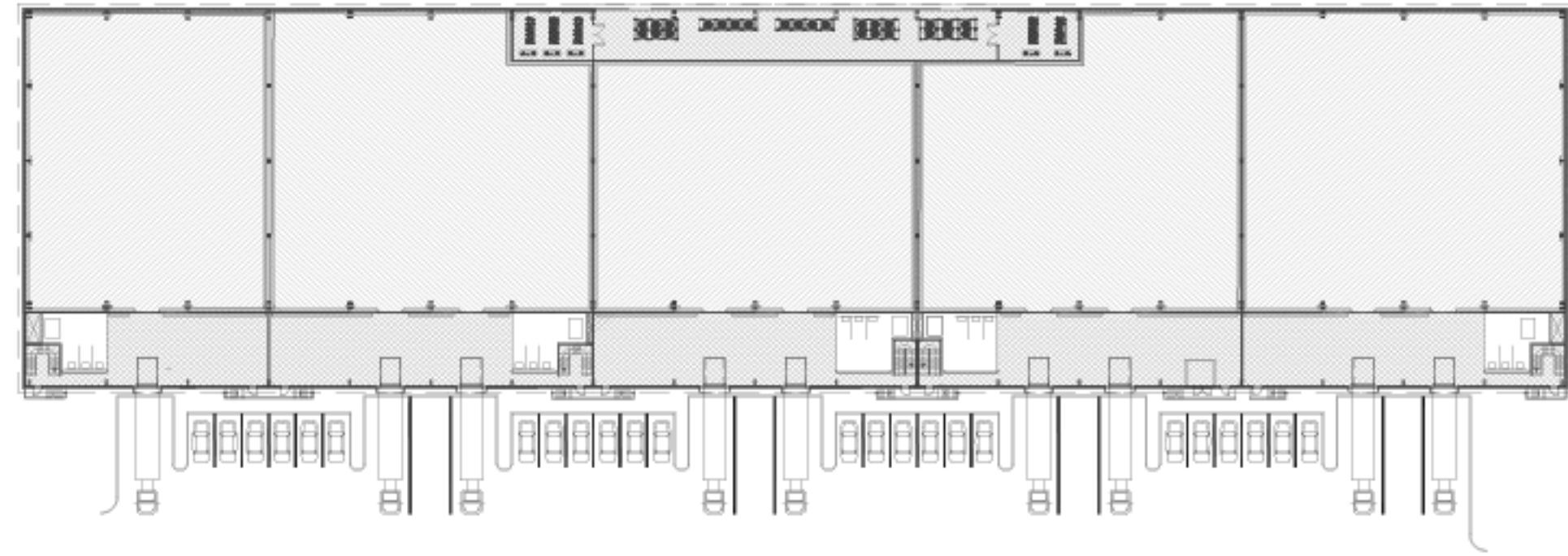

TYPE A 1,203 M² **TYPE B** 1,532 M² **TYPE C** 1,382 M² **TYPE D** 1,472 M² **TYPE E** 1,603 M²

CHILLED-CH2-MEZZANINE FLOOR

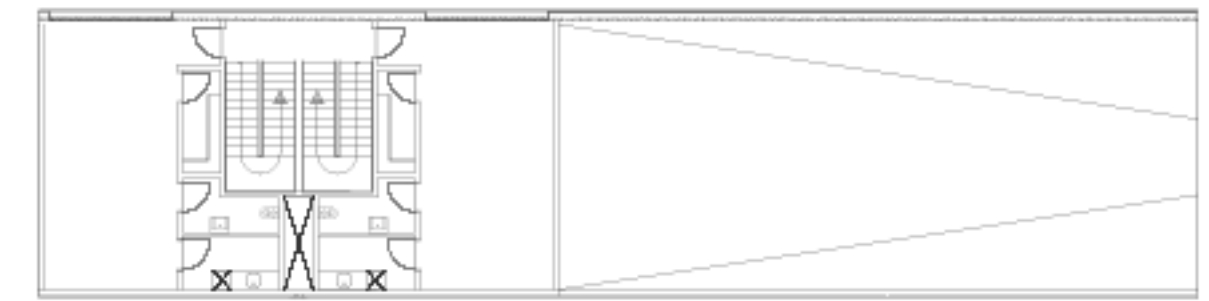
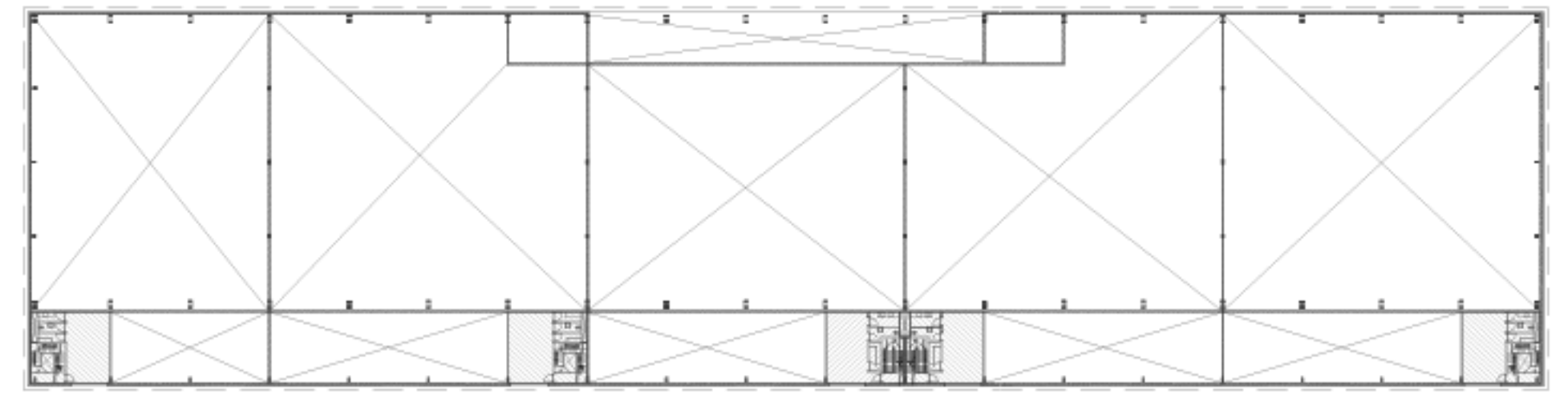

Each Warehouse has an Office of 77 m², including a pantry and a bathroom in the Mezzanine floor.

CHILLED-CH3-GROUND FLOOR

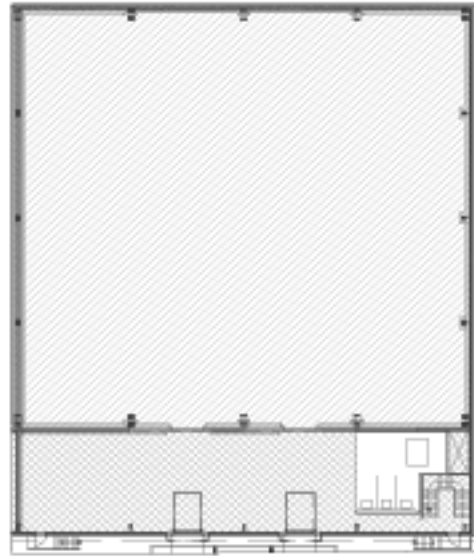
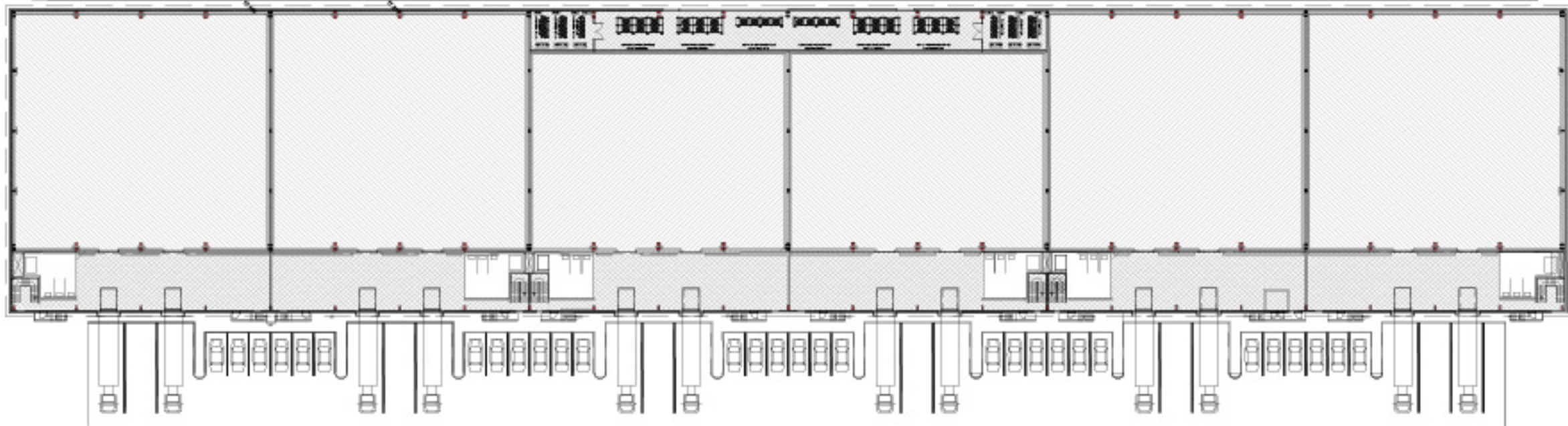

TYPE A
1,583 M²

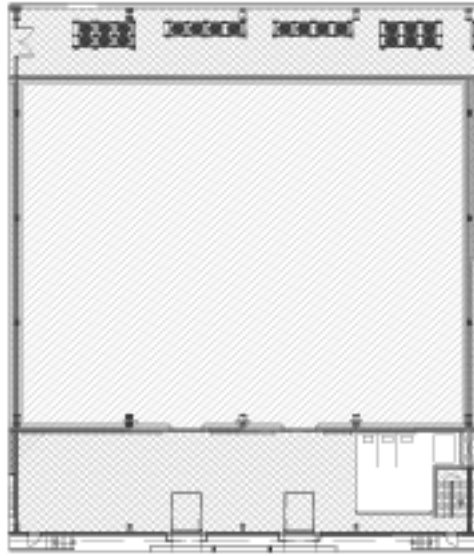

TYPE B
1,382 M²

CHILLED-CH3-MEZZANINE FLOOR

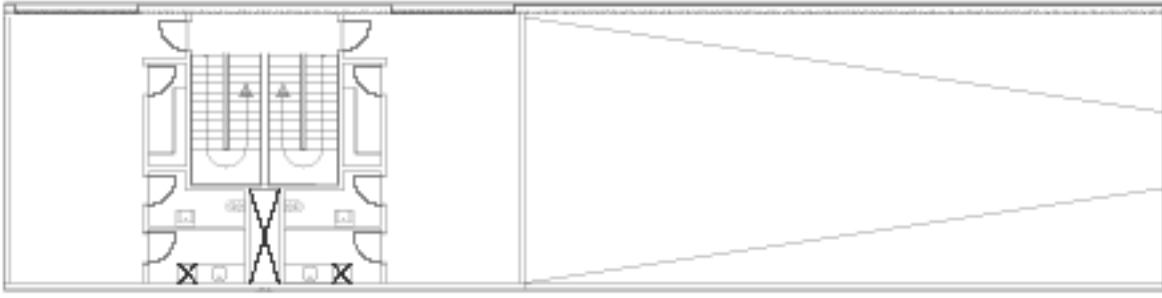
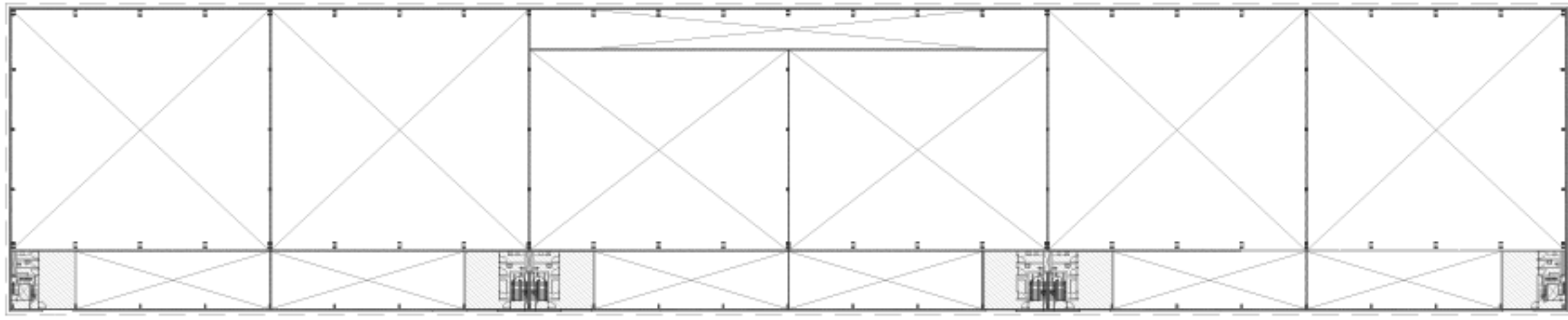

Each Warehouse has an Office of 77 m², including a pantry and a bathroom in the Mezzanine floor.

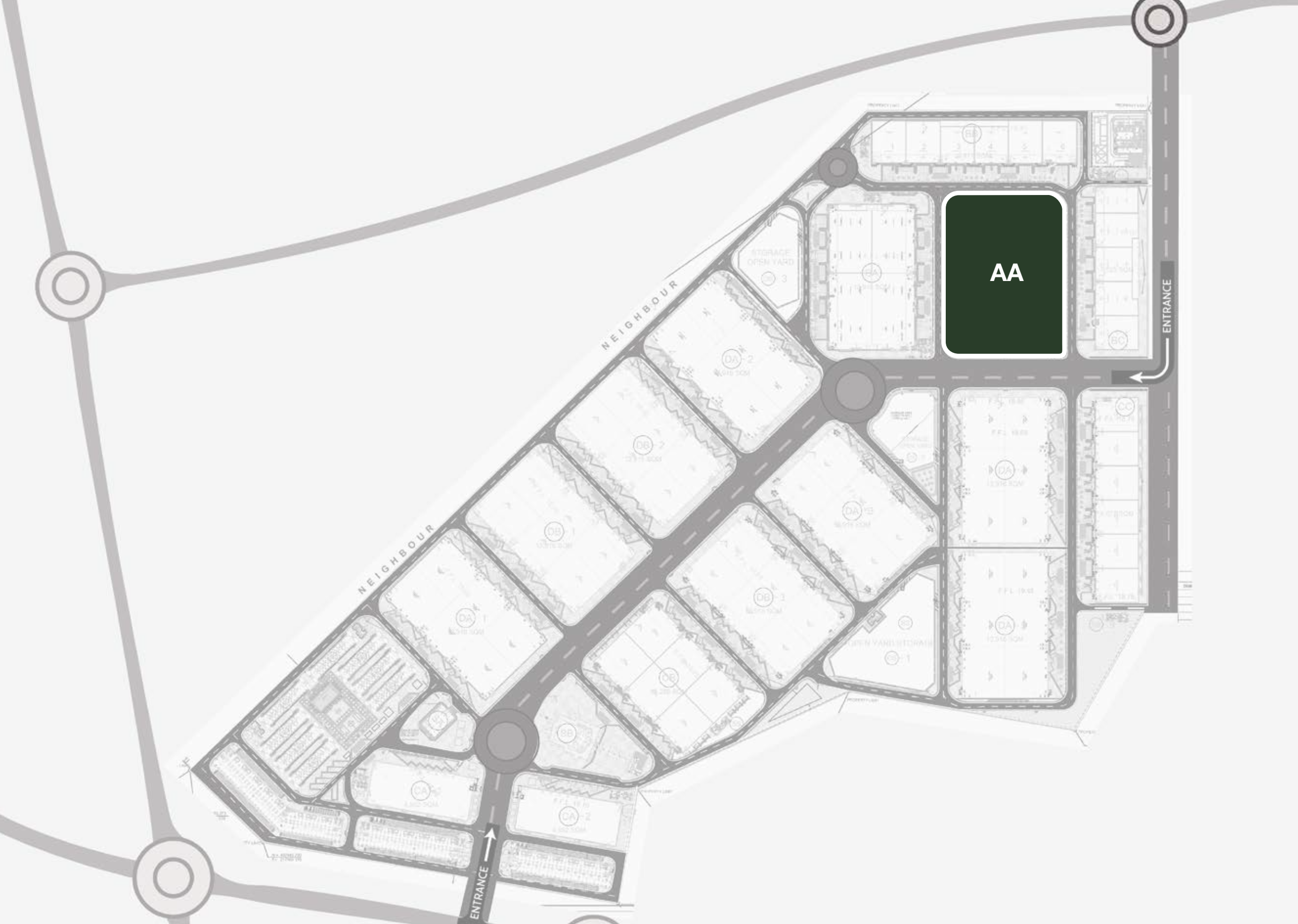

FROZEN STORAGE WAREHOUSES

AA (Ground Floor, Mezzanine Floor)

FROZEN STORAGE -AA-GROUND FLOOR

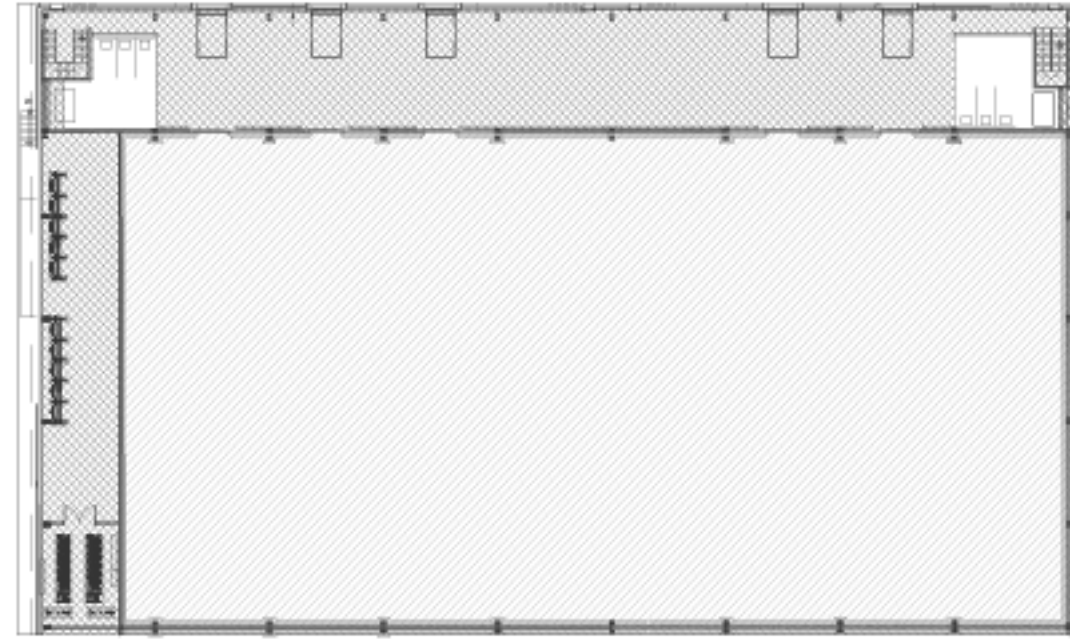
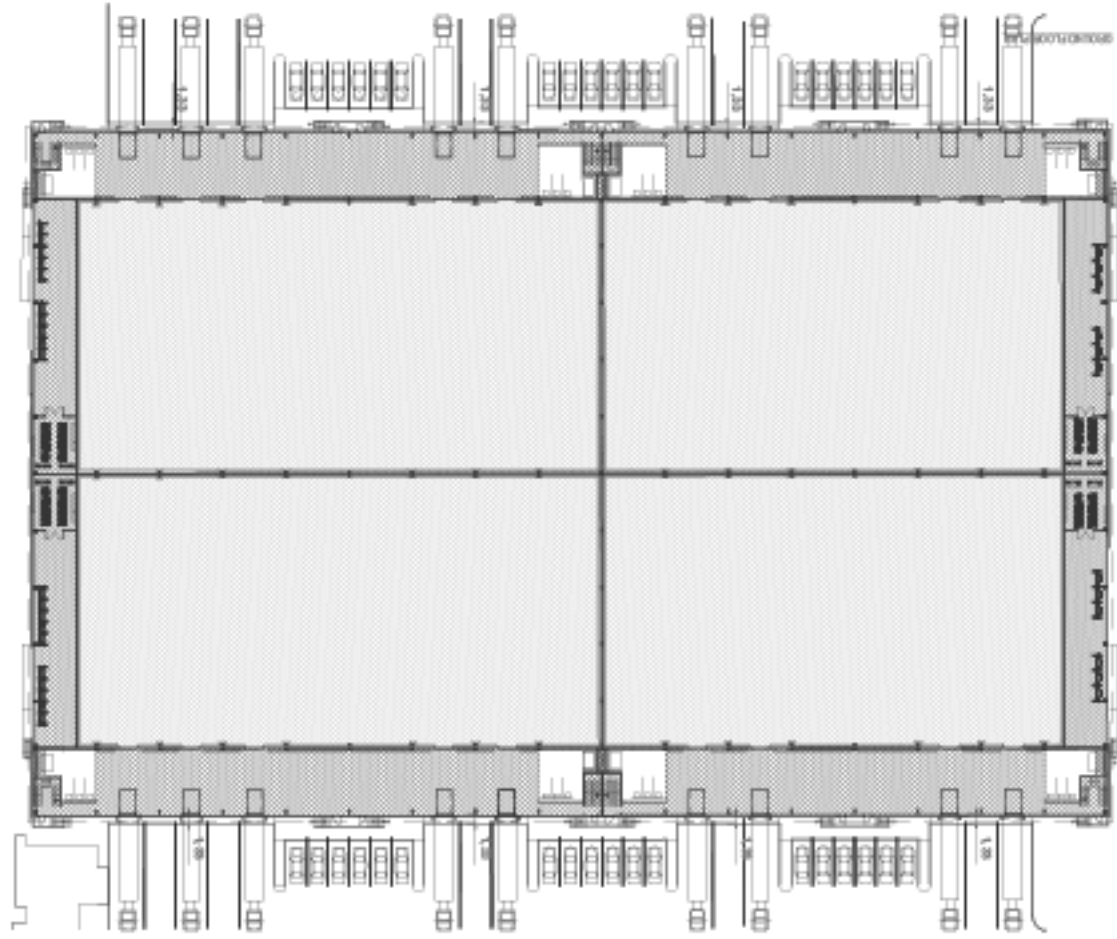

TYPE A
3,605 M²

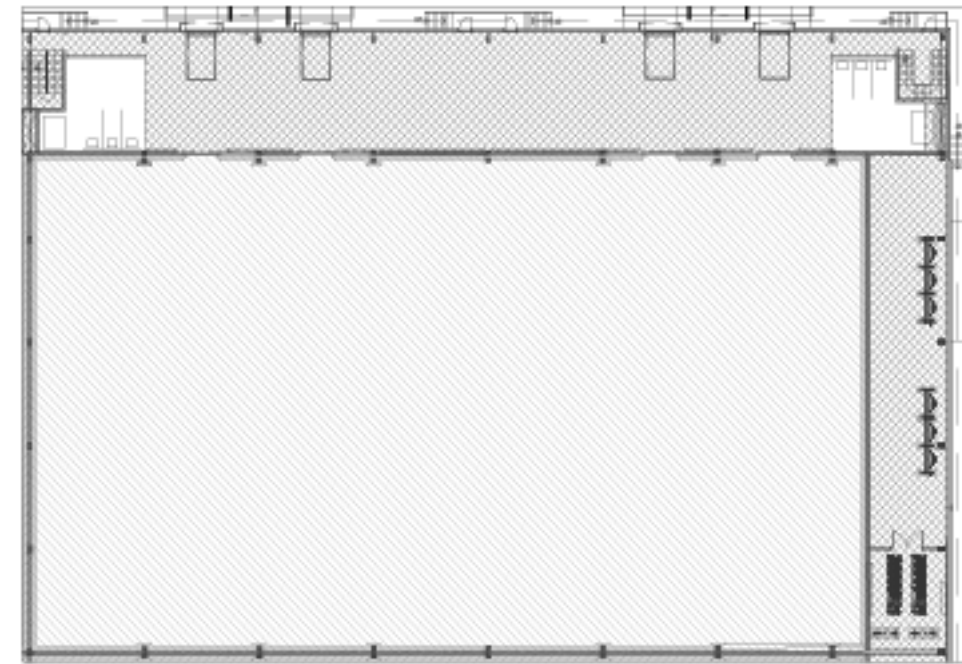

TYPE B
3,212 M²

FROZEN STORAGE -AA-MEZZANINE FLOOR

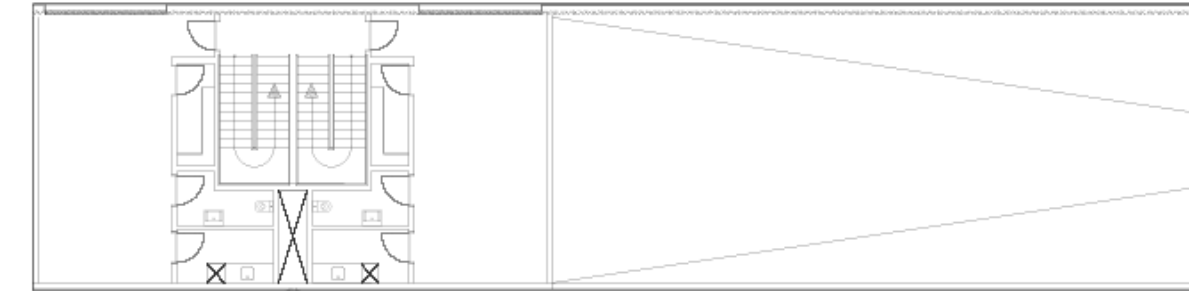
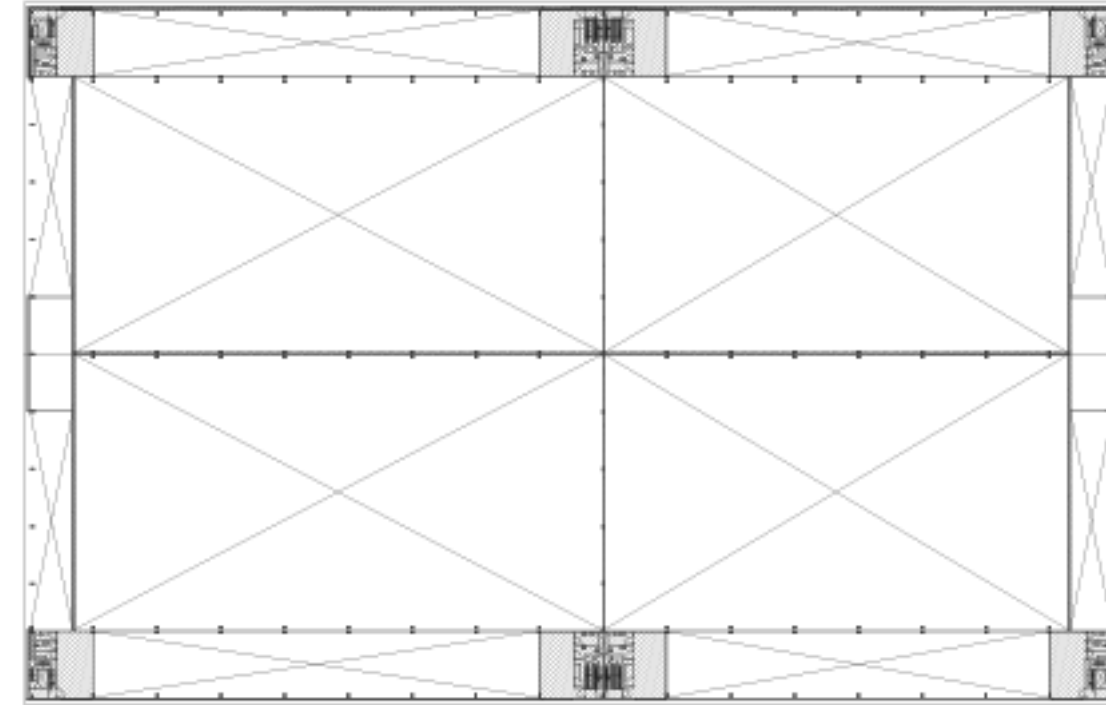

Each Warehouse has an Office of 77 m², including a pantry and a bathroom in the Mezzanine floor.

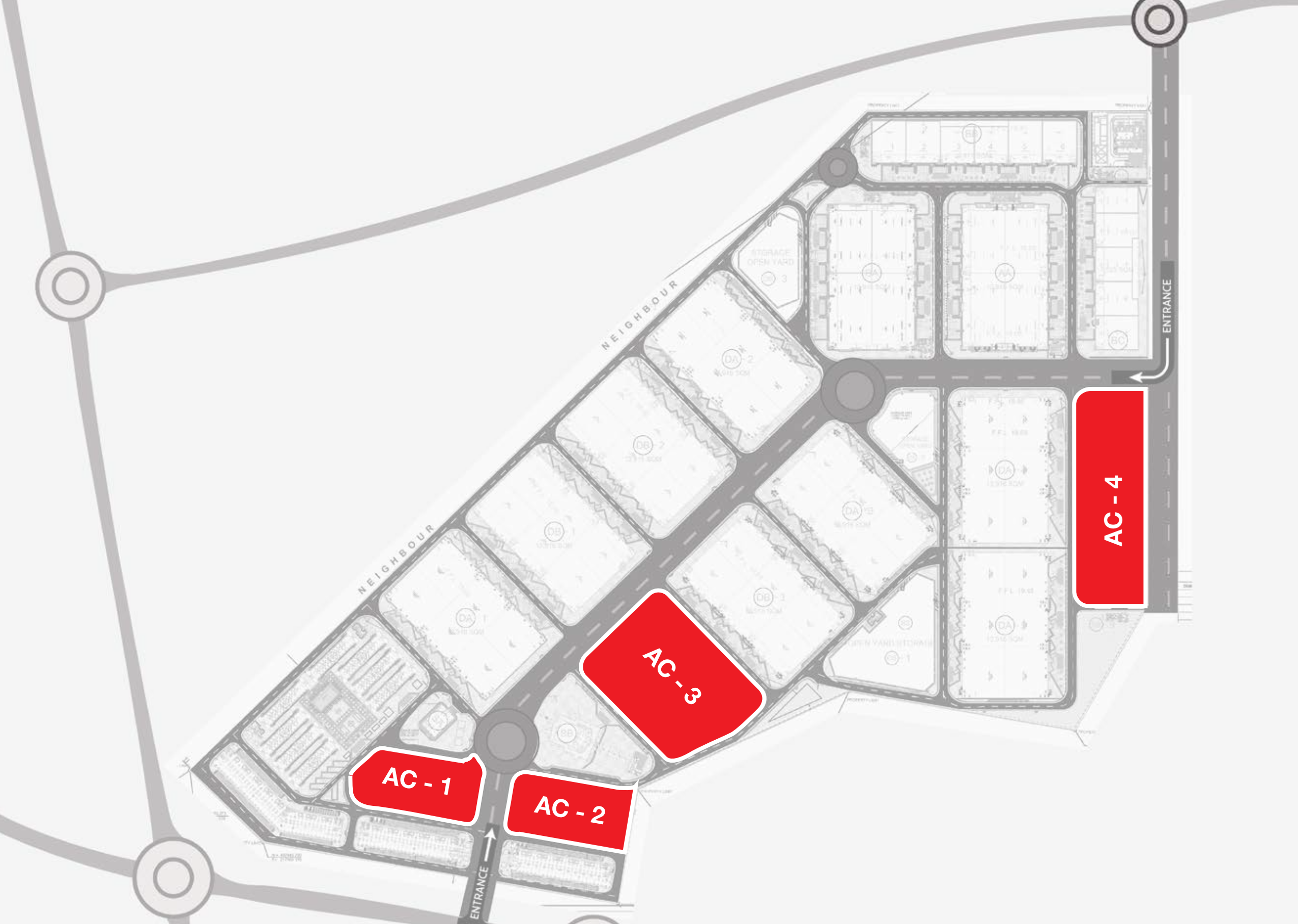

AIR CONDITIONED WAREHOUSES

- AC -1
- AC -2
- AC -3
- AC -4

AIR CONDITIONED-AC1



5,026 M²

Each Warehouse has an Office of 35 m² and a battery charging room of 35 m²

AIR CONDITIONED-AC2

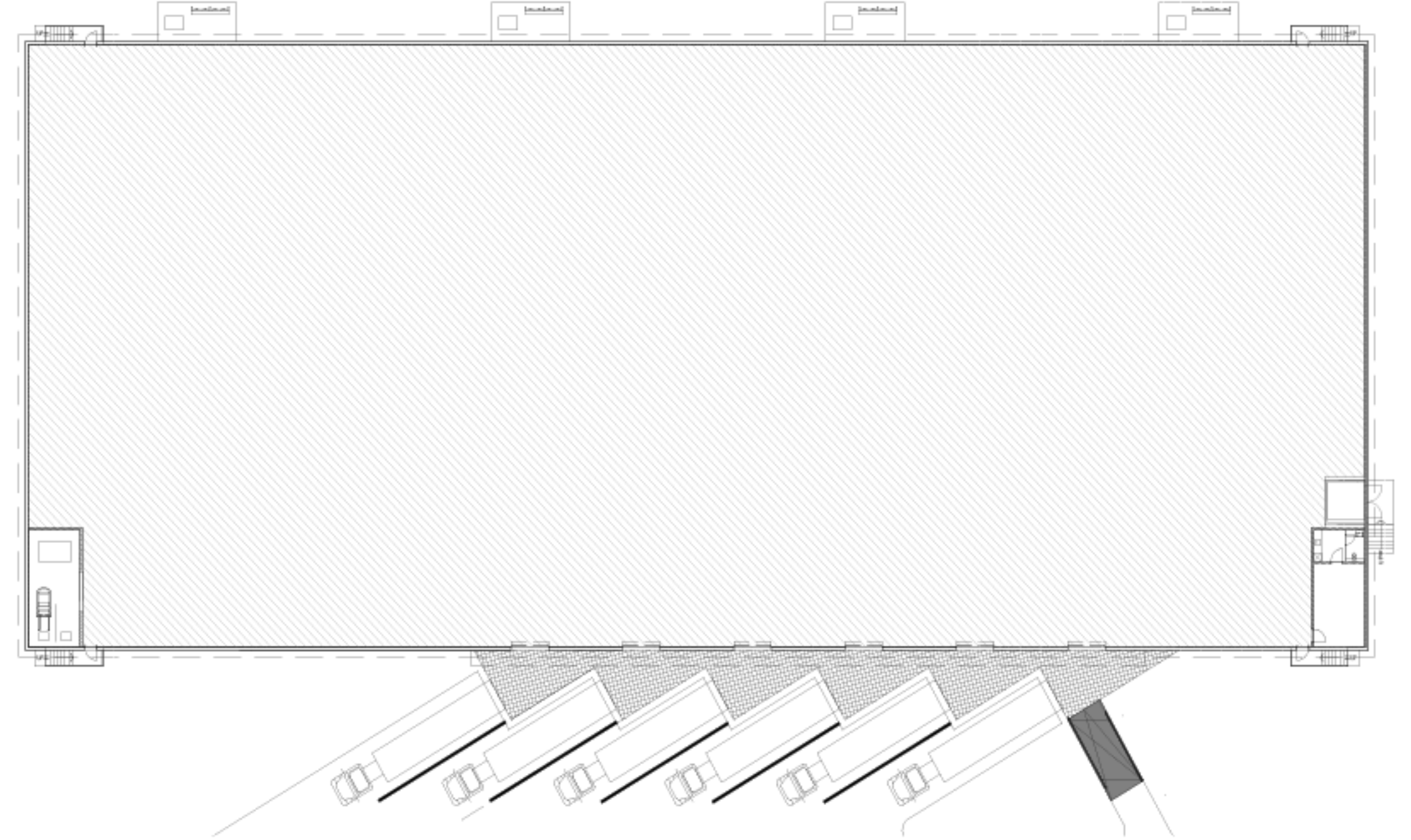

5,026 M²

Each Warehouse has an Office of 35 m² and a battery charging room of 35 m²

AIR CONDITIONED-AC3

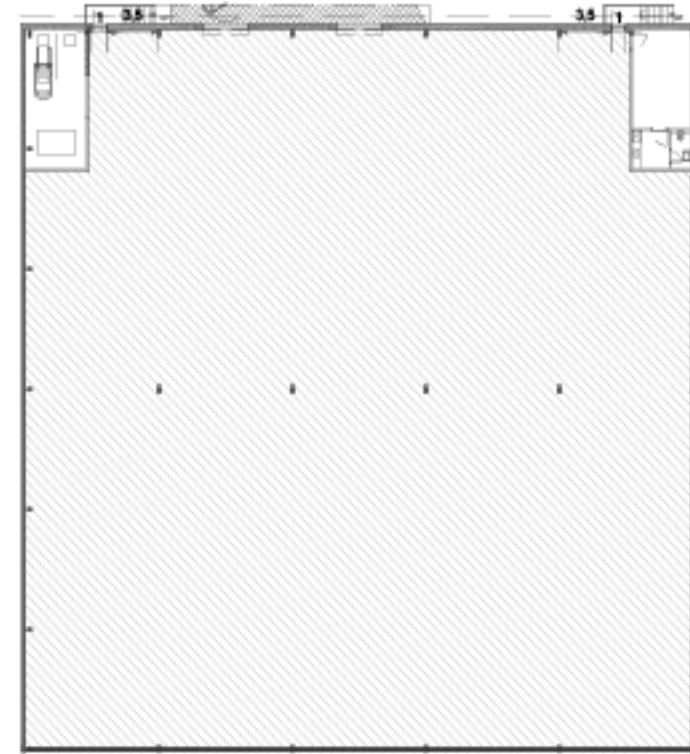
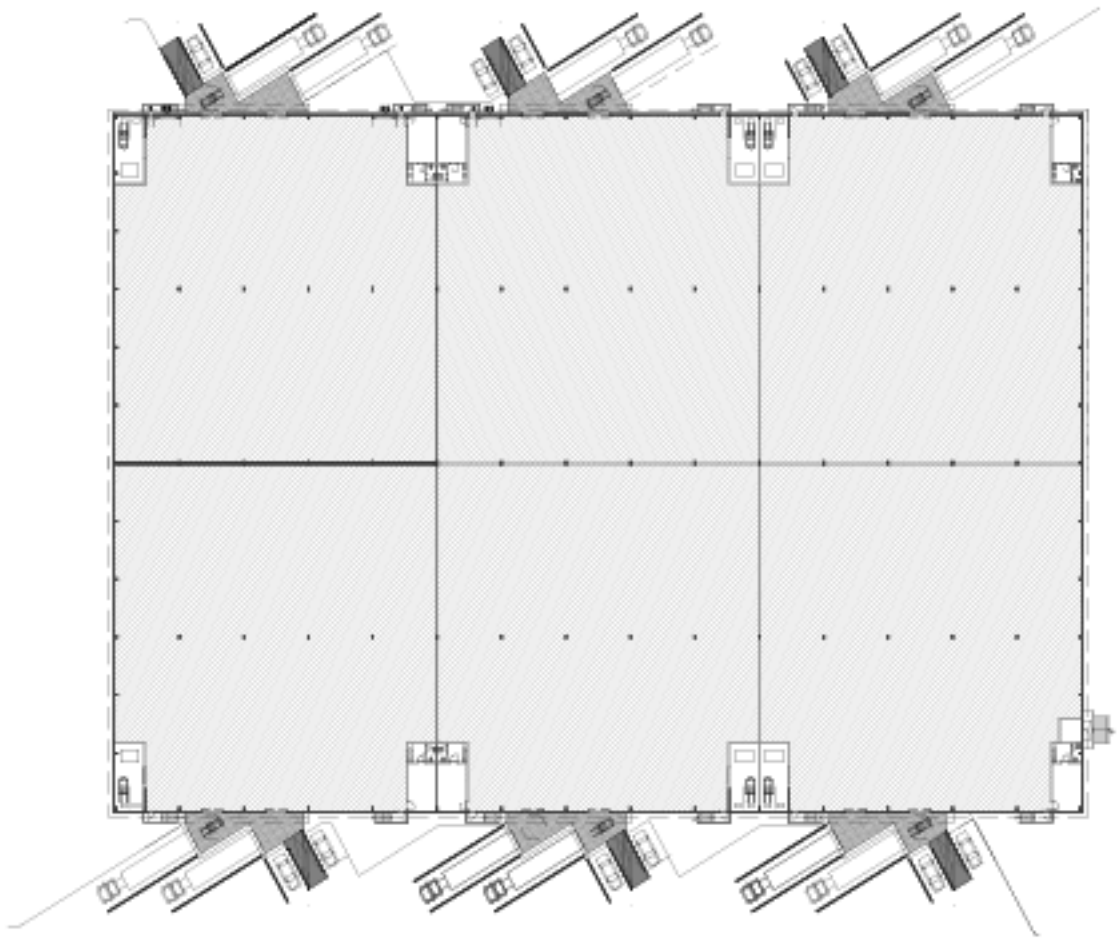

TYPICAL TYPE
2,065 M²

Each Warehouse has an Office of 35 m² and a battery charging room of 35 m²

AIR CONDITIONED-AC4

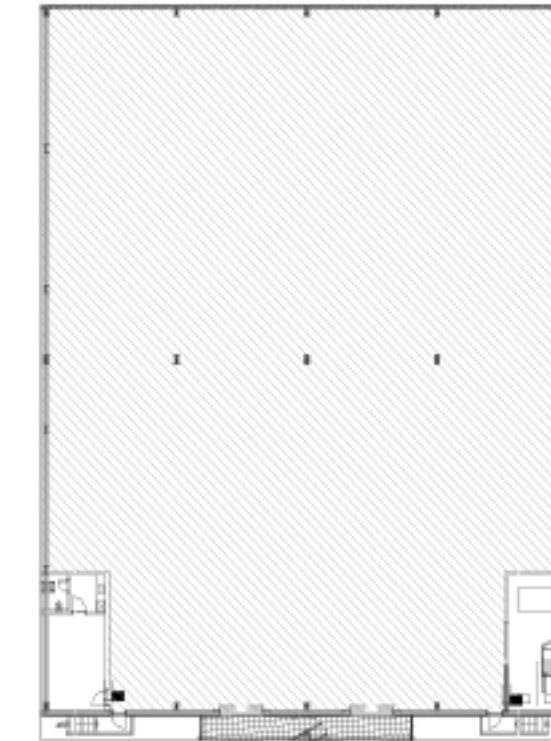
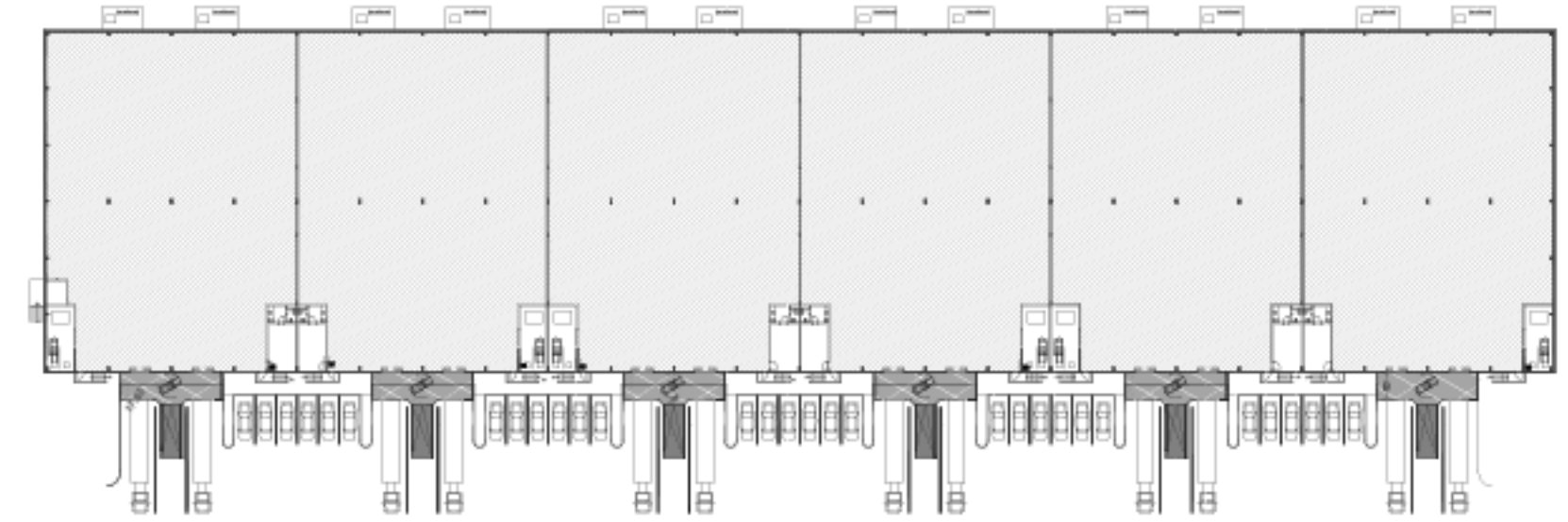

TYPICAL TYPE
2,065 M²

Each Warehouse has an Office of 35 m² and a battery charging room of 35 m²

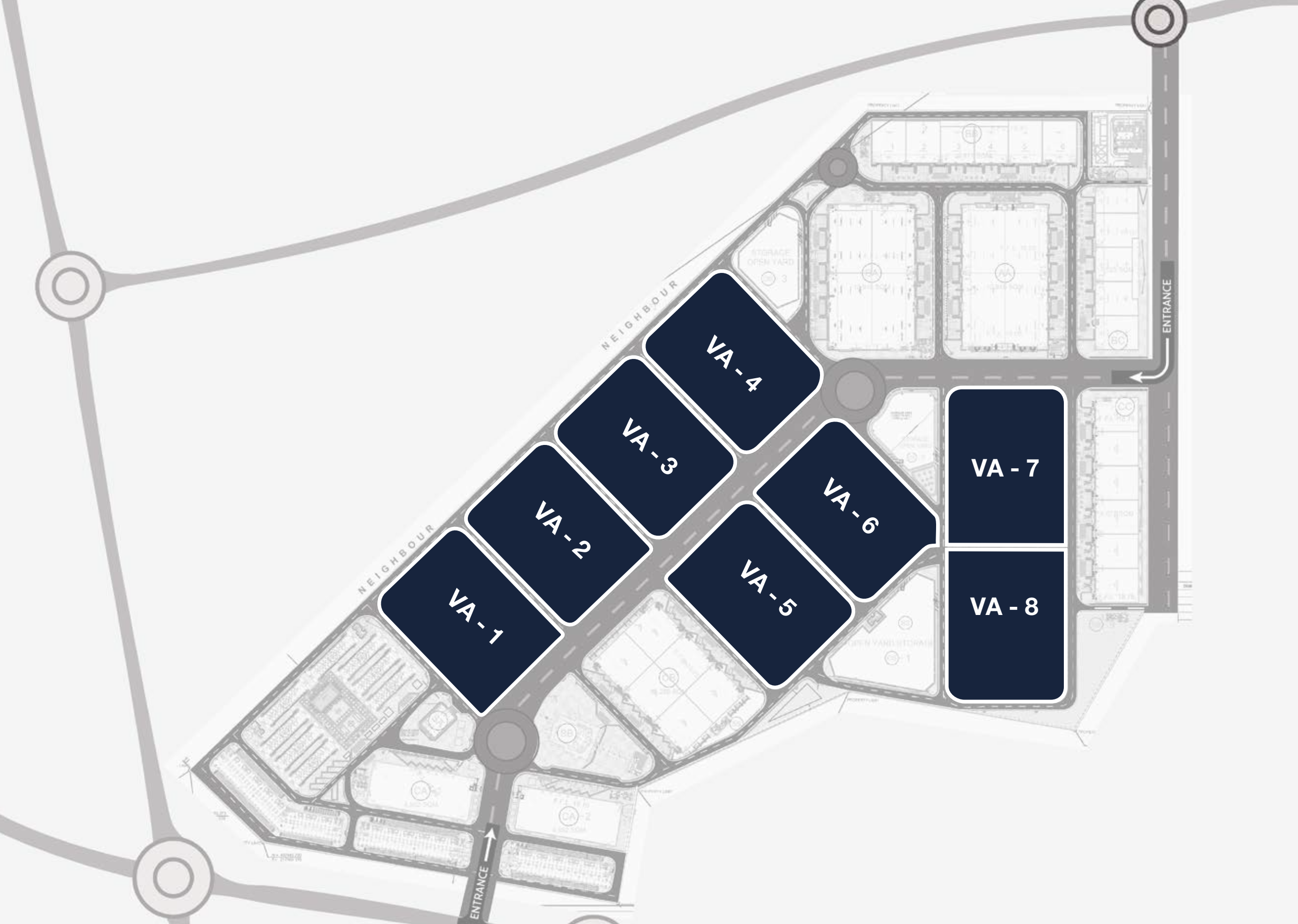

VENTILATED WAREHOUSES

- VA -1
- VA -2
- VA -3
- VA -4
- VA -5
- VA -6
- VA -7
- VA -8

VENTILATED - VA1, VA2, VA3, VA4, VA5, VA6, VA7& VA8

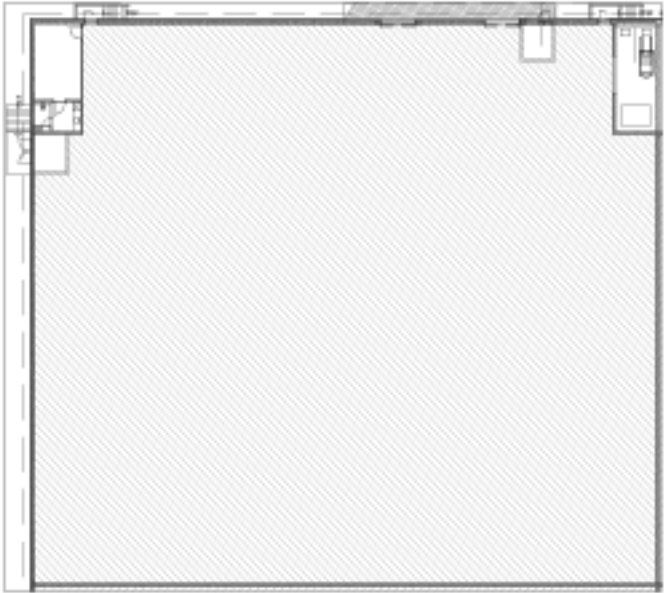
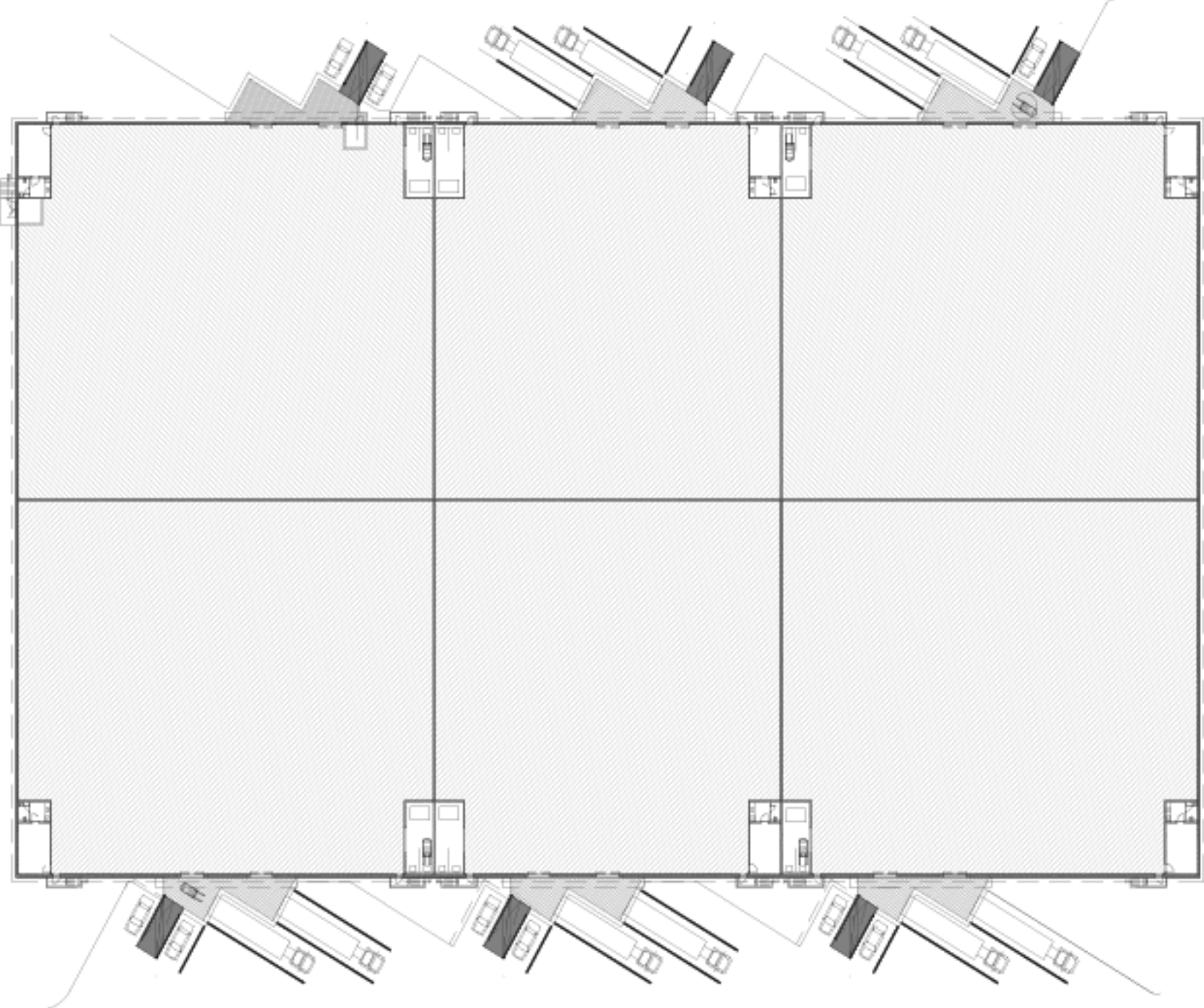

TYPE A
2,470 M²

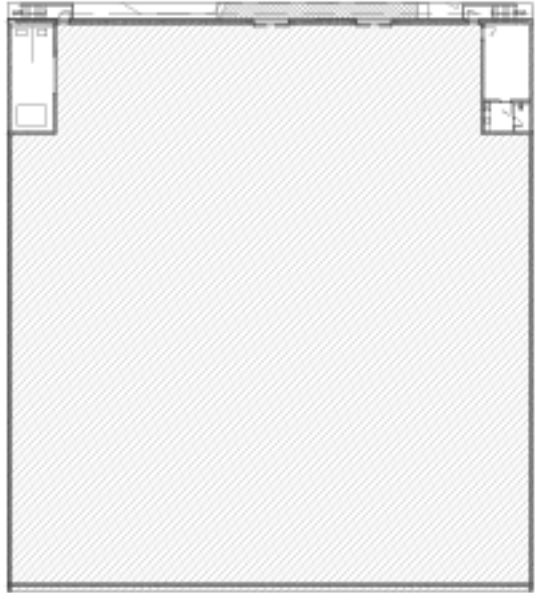

TYPE B
2,475 M²

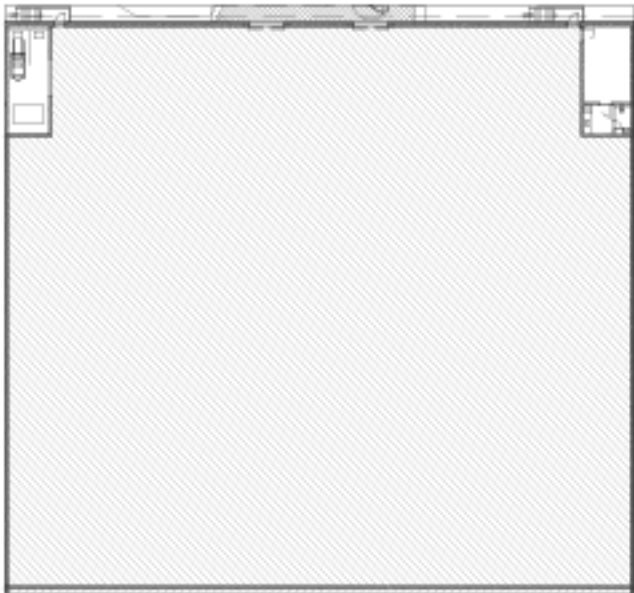

TYPE C
2,065 M²

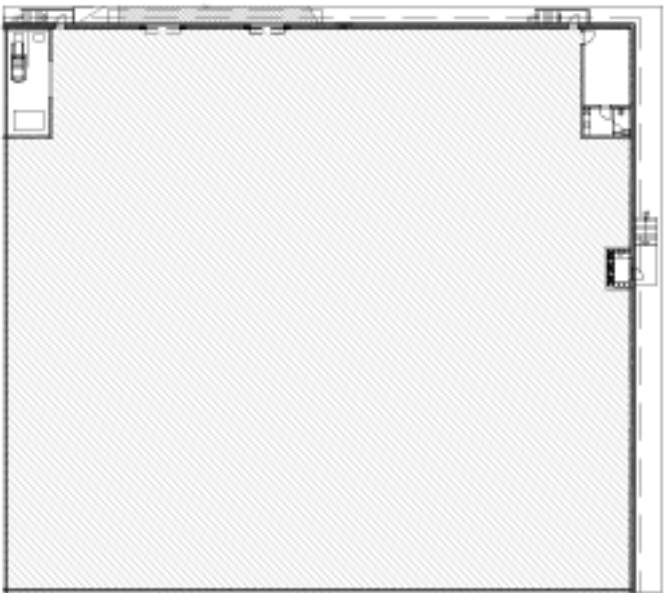

TYPE D
2,455 M²

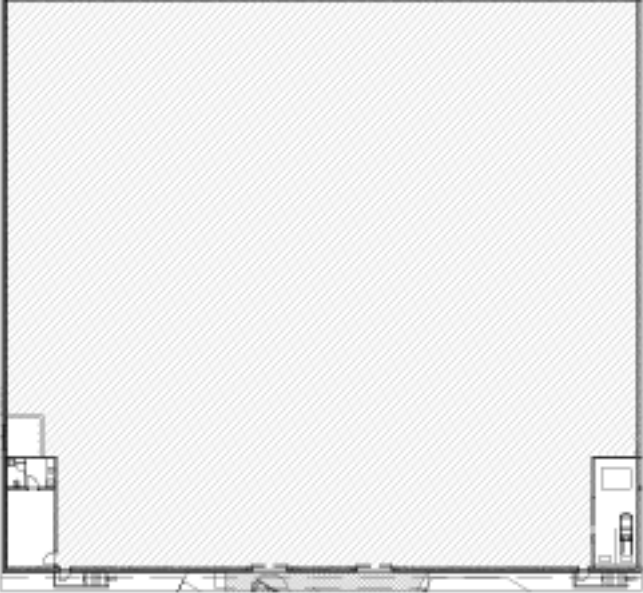

TYPE E
2,490 M²

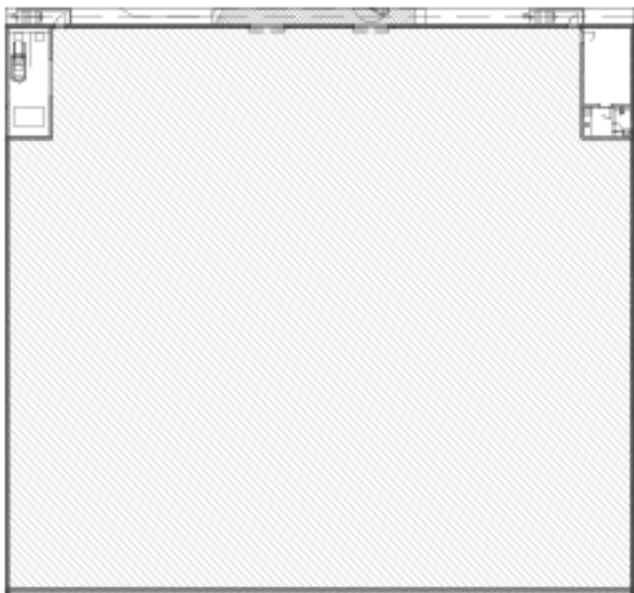

TYPE F
2,481 M²

Each Warehouse has an Office of 35 m² and a battery charging room of 35 m²

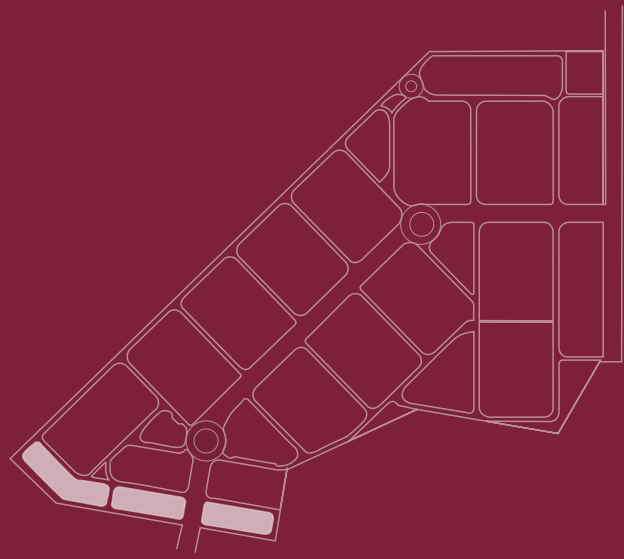

SHOP

R E T A I L S H O P S

RETAIL SHOPS

The commercial atrium is home to retail shops of 330 square-meter each, split-up into 2 layers by a mezzanine divider.

A total of 43 retail shops are distributed among 3 buildings, overlooking the access to the Orbital road through full-glazed facades; two buildings will be dedicated for building materials outlets while the third is reserved for life support (supermarket, pharmacy, ATM, phones accessories, laundry and catering)



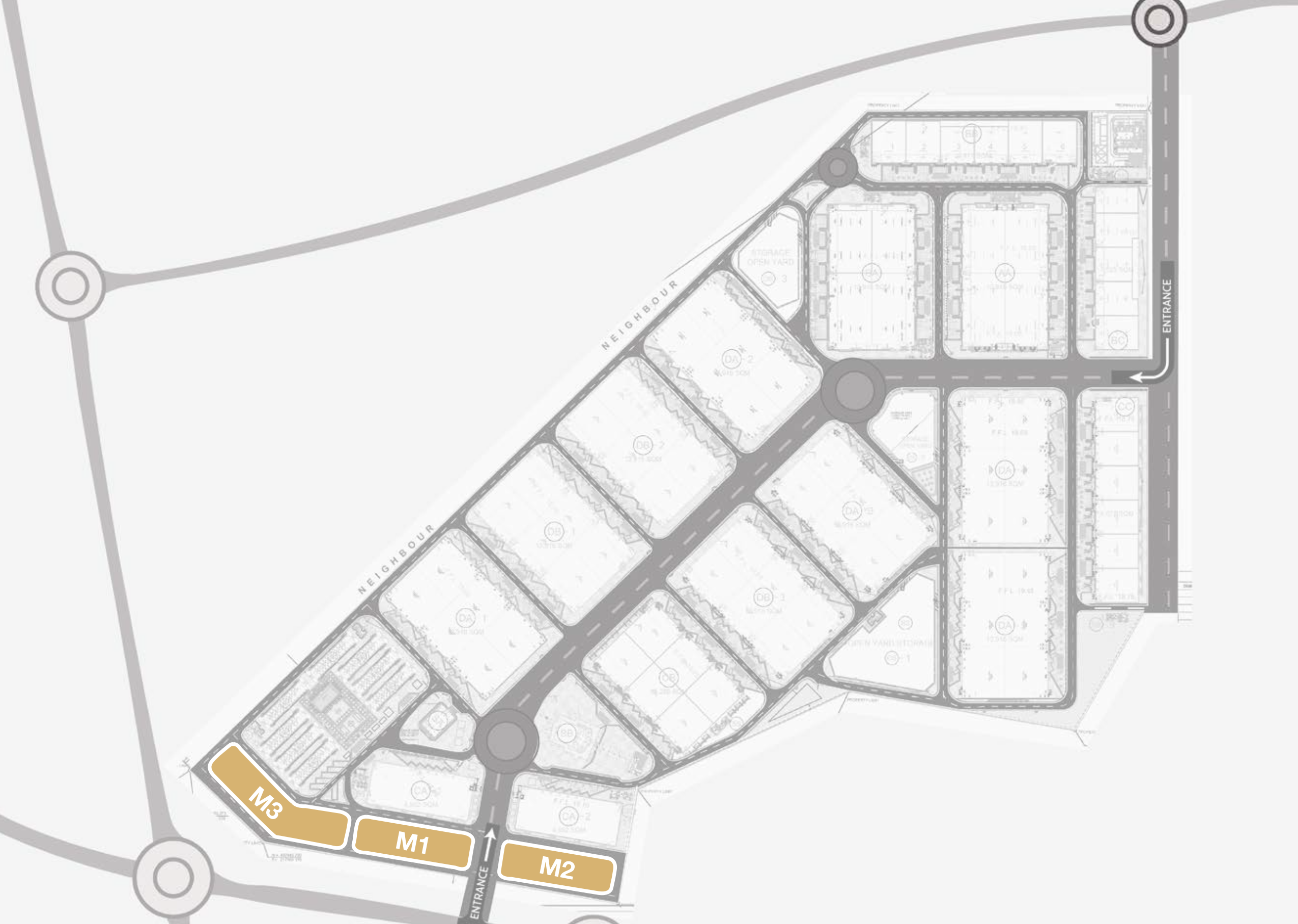

RETAIL SHOPS

- M1
- M2
- M3

SHOPS-M1-GROUND FLOOR & MEZZANINE FLOOR

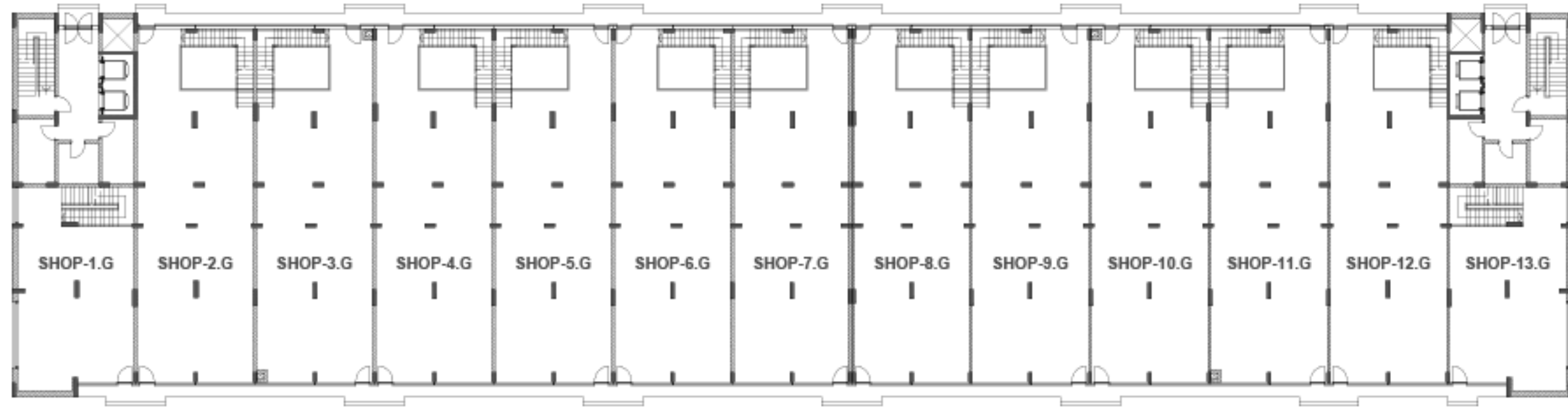

GROUND FLOOR



MEZZANINE FLOOR

SHOPS-M1-MEZZANINE FLOOR

TYPE A : 333 M²



Ground Floor : 193 M



Mezzanine Floor : 140 M²

TYPE B : 190 M²

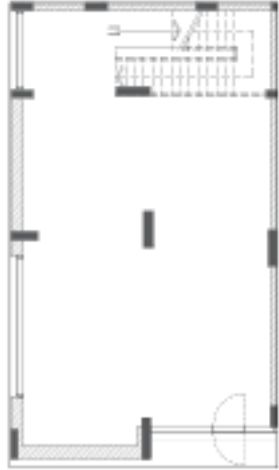

Ground Floor : 110 M²

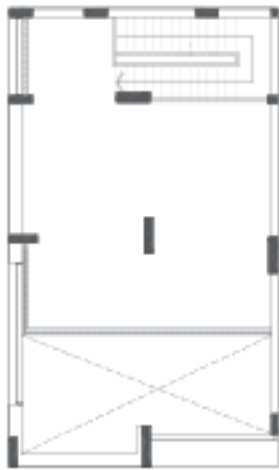

Mezzanine Floor: 80 M²

SHOPS-M2-GROUND FLOOR & MEZZANINE FLOOR



GROUND FLOOR

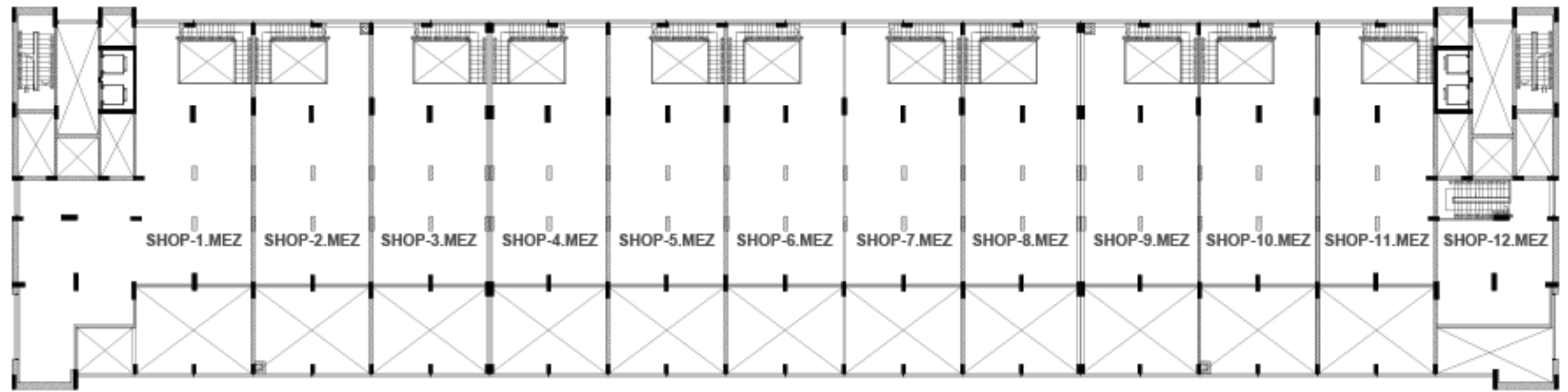

MEZZANINE FLOOR

SHOPS-M2- SHOP TYPES

TYPE A : 333 M²

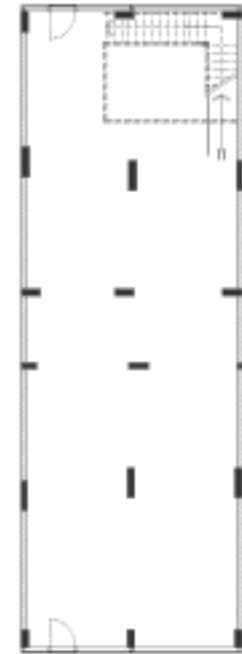

Ground Floor : 193 M²

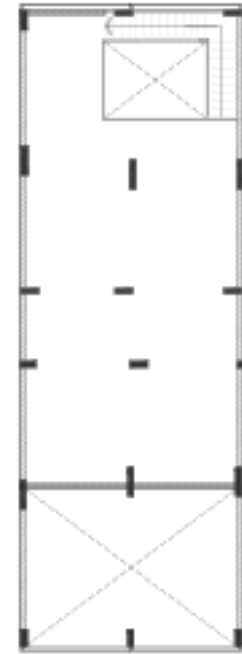

Mezzanine Floor : 140 M²

TYPE B : 190 M²

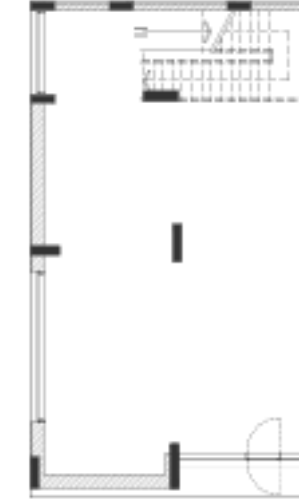

Ground Floor : 110 M²

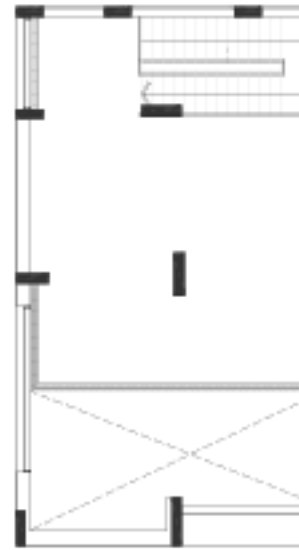

Mezzanine Floor: 80 M²

TYPE C : 480 M²

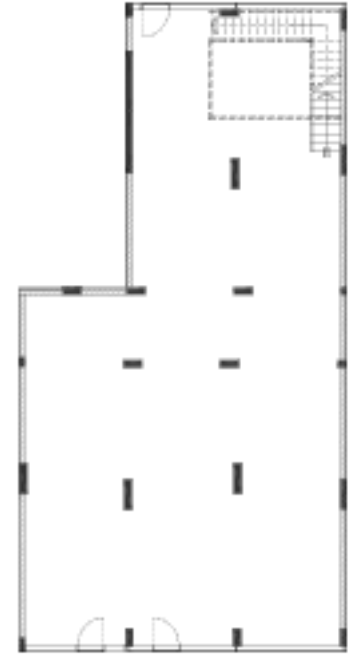

Ground Floor : 250 M²

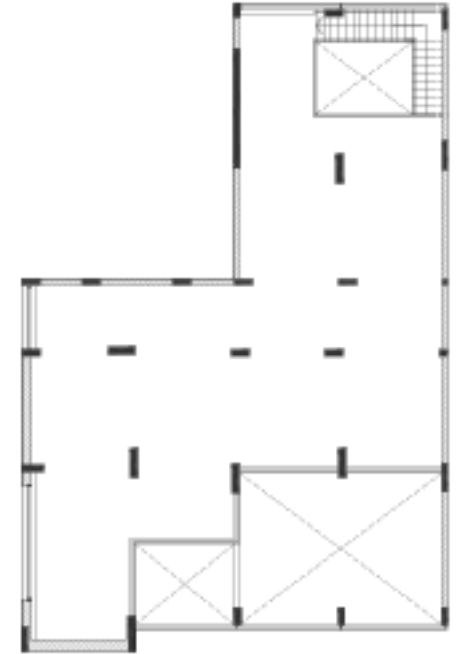

Mezzanine Floor: 230 M²

SHOPS-M3-GROUND FLOOR & MEZZANINE FLOOR



SHOPS-M3- SHOP TYPES

TYPE A : 333 M²



Ground Floor : 193 M²

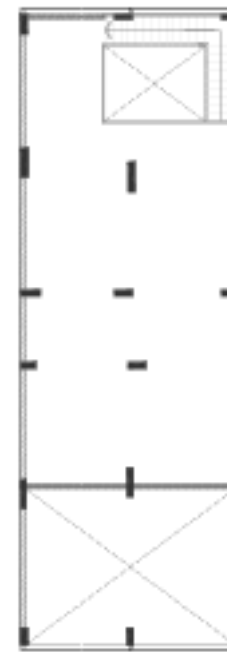

Mezzanine Floor : 140 M²

TYPE B : 190 M²



Ground Floor : 110 M²

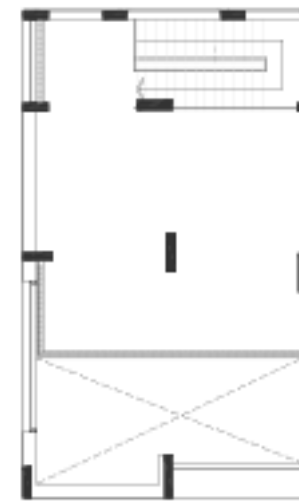

Mezzanine Floor: 80 M²

TYPE C : 740 M²

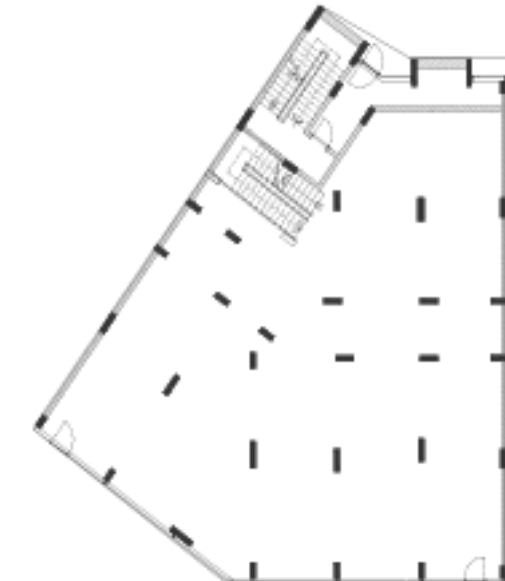

Ground Floor : 495 M²

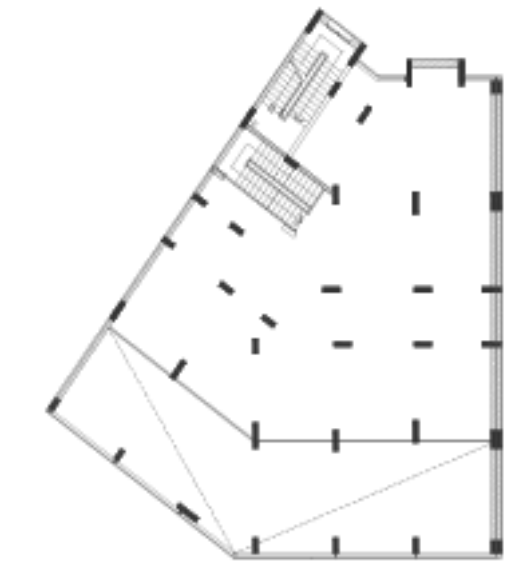

Mezzanine Floor: 245 M²

TYPE D : 260 M²

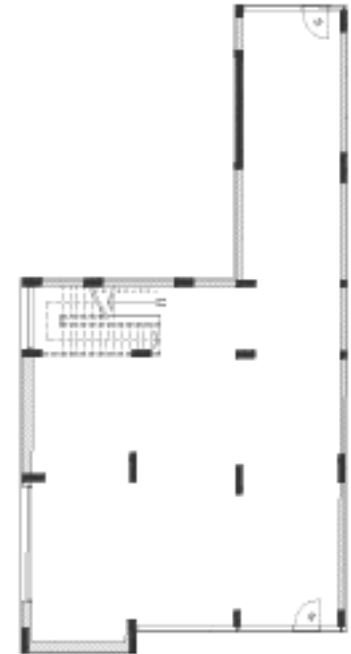

Ground Floor : 130 M²



Mezzanine Floor: 130 M²



Recreational Facilities



Community Center



Wi-Fi



Mosque



Parking



Security



CCTV



Community Center

Mosque

Parking

24 Hours Security

CCTV

Gated Community

Wi-Fi on request

Recreational Facilities

AMENITIES



alasmakhrealestate.com

Tel +974 4448 5111 Fax +974 4435 4728

P.O.Box 15068 , Doha, Qatar